



Sealing Integrity Management

# SIM

System  
for flow control



Simple Safe Assured

# Improving The Performance of Wells

Through advanced downhole technology

The SIM\* sealing integrity management system integrates a wide range of superior-performing nippleless flow control devices that can be deployed on slickline across most industry tubing sizes. Since its initial development in 2005 by Peak Well Systems, the SIM system catalog has been significantly extended as it has become the flow control technology of choice for leading operators around the world.



# Sealing Integrity Management

SIM system for flow control

The SIM system provides an extensive range of slickline-conveyed and -recoverable devices for a broad array of well intervention and production enhancement purposes anywhere within the tubing.

The SIM system enables operators to deploy flow control devices, such as the highly effective SIM system retrievable bridge plug, that deliver ultimate flexibility for well intervention, remediation, and well integrity operations as well as helping improve hydrocarbon production from multiple-zone monobore completions. Its unique patented design makes it possible to reduce operating costs and removes potential safety hazards inherent with conventional systems.

The product range of numerous interchangeable modular components is all built around the SIM system running tool as the primary means of deployment on traditional slickline. All of the SIM system modules are also fully compatible with other conveyance systems and can also be deployed on digital slickline, e-line, tractor, and coiled tubing:

- plug systems—both permanent and retrievable options
- mechanical leak detection tool—for identifying leak paths
- straddle—for zonal isolation
- gas lift straddle—for optimized well lift
- sand screen straddle—for remedial sand control
- interchangeable choke—for production control
- gauge hangers—for production and well test monitoring
- FloWell\* formation damage removal technology—for targeted well stimulation and cleanup.

### SIM system highlights:

- SIM system plugs are designed to be set anywhere in the tubing string without the need for a nipple profile.
- Advanced mechanical setting mechanism eliminates the need for complex setting tools, pyrotechnics, or explosives.
- Standard slickline package deployment facilitates logistics in remote locations.
- SIM system availability spans slim 2 3/8-in wells to large 7-in wells.



# Technology Overview

Using the SIM system means that flow control devices can be easily introduced at any point in the wellbore without the need for a nipple profile and using only simple slickline operations. This provides operators with a safety-enhanced, reliable, and cost-effective approach to managing multiple and complex producing zones.

The SIM system plugs each comprise a plug and expandable seal that do not require a landing profile and can be set by mechanical toolstring manipulation. The system is facilitated by the slickline-conveyed SIM system running tool that enables the user to land the toolstring at any desired depth within the tubing.

A radial indexing mechanism activates a set of slips to anchor the SIM system running tool to the tubing wall. The device is then simply set by downward jarring, which consequently activates and expands the sealing element. An overpull is applied to confirm that the deployed component has been fully set. Once the device is confirmed to be set in place, the SIM system running tool is released from the device by upwards jarring.

The user-friendly running and setting method of the SIM system is consistent with the core skill sets of slickline personnel around the world, making the SIM system an ultrareliable specialist tool for everyday operations.

Using a similar process, the SIM system running tool is used to deploy Peak Well Systems gauge hangers to carry data acquisition devices or to be set as anchors to provide a platform for instruments that require suspension in the wellbore.

For applications where setting depth control is critical, products within the SIM system can also be deployed and set on e-line using standard electrohydraulic or pyrotechnic setting tools.

The user-friendly running and setting method of the SIM system is consistent with core skill sets of slickline personnel around the world, making the SIM system an ultrareliable specialist tool for everyday operations.

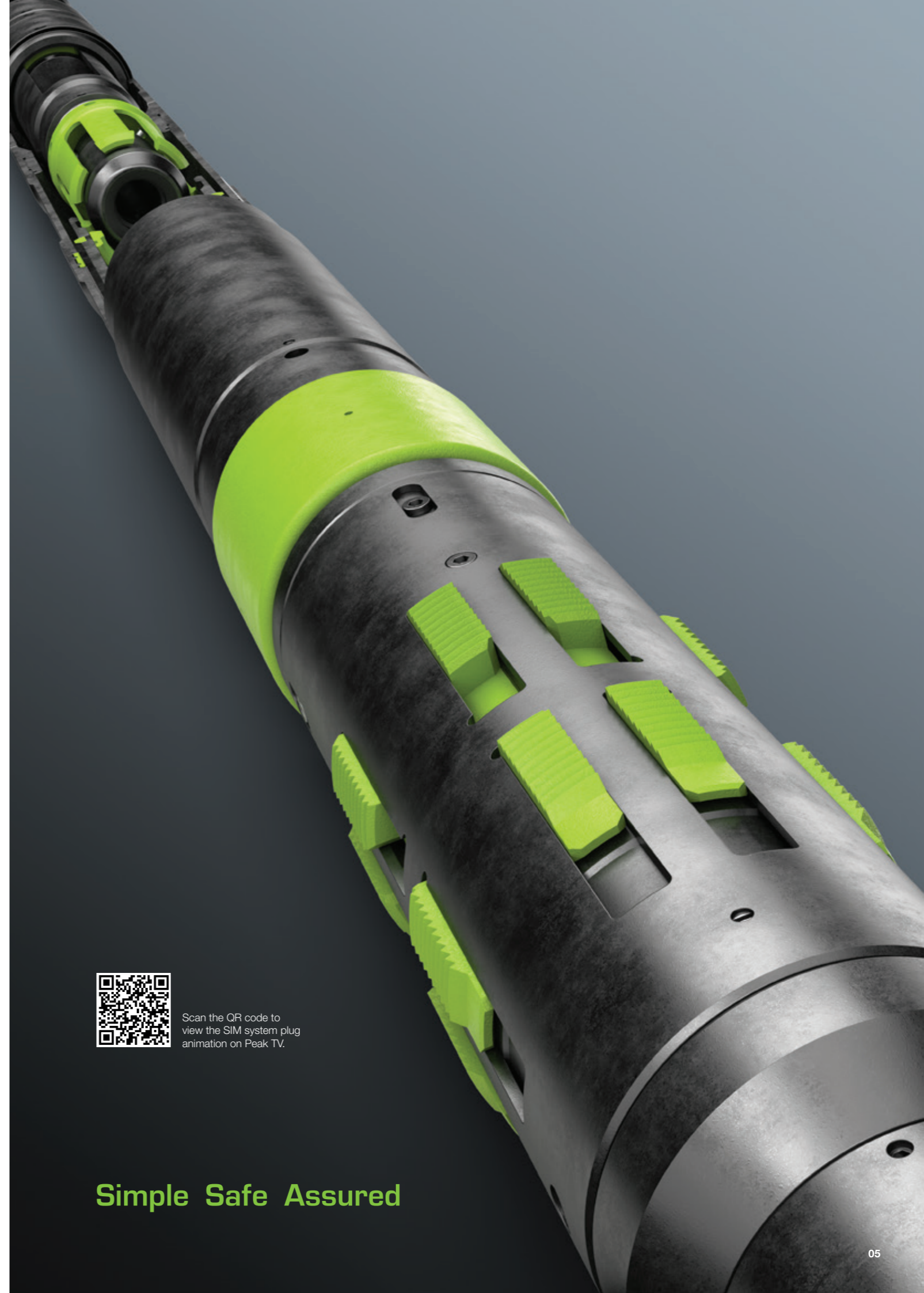

Scan the QR code to view the SIM system plug animation on Peak TV.

## Simple Safe Assured

# SIM System Applications

The SIM system has many different applications in the management and monitoring of producing zones through slickline intervention and it can also perform as a permanent barrier in well abandonments. These are all based on and built from the basic SIM system plug chassis and the associated SIM system running tool:

- When the SIM system plug body is fitted with an elastomeric element, it can be deployed as a certified well barrier, capable of holding differential pressure in both directions. To ensure the safest and most reliable recovery, the plug is available with a wide selection of equalizing options to suit different operations and well conditions.
- The SIM system plug can be used for isolation or as a flow-through device, with applications for the latter including as a suspension mechanism for carrying other flow control tools.
- When used as a flow-through device and fitted with an interchangeable choke, the SIM system plug can be used to choke back unwanted or excess gas production downhole.
- For zonal isolation, the SIM system plug can be run alone or combined into an upper and lower plug pair connected by the stackable Peak Well Systems straddle system to provide isolation over a designated well interval.
- The straddle assembly can also be fitted with the Peak Well Systems integral gas lift valve to provide downhole gas lift either from a straddled gas-producing zone or from the annulus via a tubing punch.
- FloWell formation damage removal technology is a unique application that uses SIM system plugs to isolate a zone for subjecting it to a rapid pressure drop, thereby inducing a transient underbalance that triggers surge flow through the perforation tunnels. The surge within the perforation tunnel delivers enhanced production by cleaning up drilling and perforation damage that can restrict flow into the wellbore.

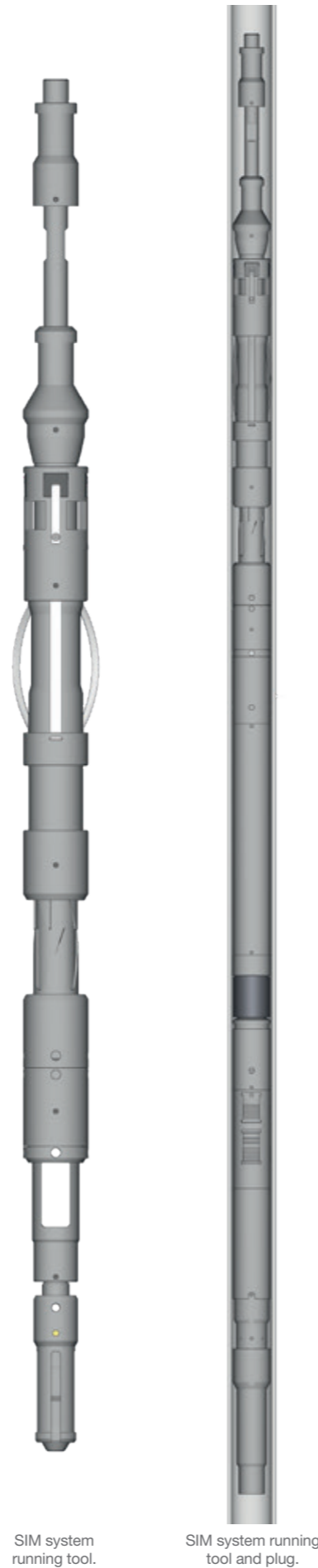

SIM system running tool.

SIM system running tool and plug.

## SIM system plug bomb hanger

In its simplest form, the SIM system plug body is used as a carrier for downhole tools. In such applications, it can be used as a bomb hanger for carrying downhole gauges. The advantage of the SIM system in all cases is that it enables placing the tools as close as possible to the area of interest for pinpoint data acquisition.

## SIM system plug

When a SIM system plug is fitted with its elastomeric element and run with a melon-type or the more common prong-type equalizing assembly, it acts as a bidirectional plug to seal pressure from above and below.

Applications include

- collision barrier during drilling operations
- wellhead isolation
- zonal isolation for water shut-off
- zonal isolation to prevent cross flow/co-mingling
- packer setting and tubing tests during completions/workovers
- tubing integrity testing.

A SIM system plug can be set with a standing valve prior to re-perforating above previously perforated zones. This enables the new higher-pressure upper zone to produce without crossflow to the lower existing zone. When the pressure within the upper and lower zones equalizes, the lower zone can produce freely without the need to recover the barrier.

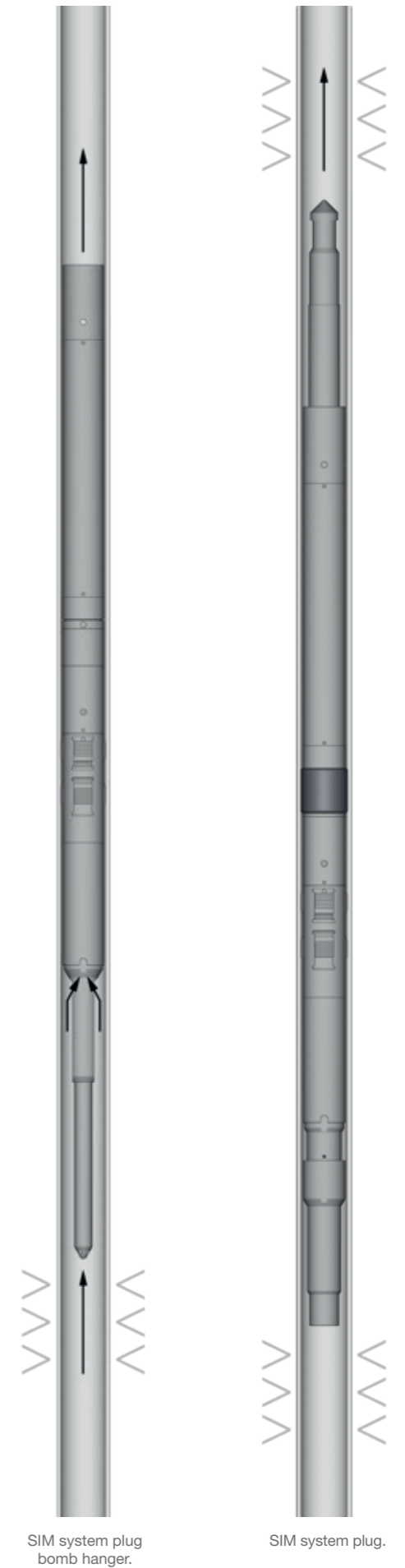

SIM system plug bomb hanger.

SIM system plug.

# SIM System Applications

## SIM system plug carrier device

Adding adapters to the SIM system plug enables using it as a carrier device for setting at any depth within the tubing where the tool needs to be positioned.

Applications of this plug configuration include

- deployment with standing valve to prevent crossflow from a newly perforated zone to a lower depleted zone
- to suspend downhole screens
- to suspend storm chokes or velocity valves
- to deploy shut-in tools to monitor pressure build-up
- to carry any other device that needs to be suspended in tubing where there is no nipple profile or the profile is damaged.

## Choke

The SIM system plug can be fitted with an internal choke for use to restrict downhole well flow as required. The unique arrangement of the plug enables recovering the downhole choke to surface without having to recover the plug body. This means that the choke can be replaced or resized to meet maintenance or production requirements in a single, low-cost, low-risk well intervention operation, without the need to pull and reset the plug.

The choke can be used to

- control oil or gas flow between two or more zones to in turn control crossflow and improve overall reservoir performance
- control gas flow from a gas reservoir below an existing oil reservoir and thus provide natural gas lift
- control gas flow from different reservoirs to give a controlled mix from the well, for example, to balance the dilution between gases with high- and low-CO<sub>2</sub> content.

**SIM system plugs provide several key benefits to operators: They are easy to transport with no heavy lifting equipment required and significantly improve both safety and operational cost because they are set mechanically. Costs are further reduced by removing the need for specialist personnel and minimizing the equipment spread required for the installation.**



SIM system plug carrier device.

Choke.

## Straddle system

The SIM system plug can be fitted with straddle tubes between the upper and lower packers to provide isolation across the straddled zone. There is no requirement for a different SIM system device—all SIM system applications use the same base plug components.

The SIM system plug design has a unique selective latch mechanism on each straddle connector to enable recovering the tubes one at a time should the straddle need to be retrieved. This is a critical safety consideration when recovering straddle sections back into the lubricator at surface and ensures that the recovered sections do not restrict the function of the Christmas tree valves.

The straddle system can be used to

- isolate water zones
- isolate unwanted gas flow
- isolate a hole in tubing
- isolate a leaking device within the tubing, such as a side pocket mandrel, sliding side door, or inflow control device (ICD).

## Integral gas lift

The Peak Well Systems integral gas lift system incorporates a gas lift choke sub or connector that is run within the straddle system to provide controlled gas flow from a gas zone behind the straddled zone. If required, the choke can be resized by recovering the uppermost straddle tube.

## FloWell formation damage removal technology

FloWell technology delivers a simple and robust method to clean up existing perforations by creating a rapid pressure drop across the face of the perforation tunnel. This transient high underbalance induces a surge flow through the perforation tunnel from the surrounding formation, which carries debris and other flow-impairing materials with it. The tool can also be used in other operations in which a rapid negative pressure drop and surging are beneficial, for example, unplugging ICDs.

FloWell technology can be used to surge

- completed cased hole intervals to improve perforation tunnel productivity
- completed intervals to overcome damage due to crush zone effects, scale buildup, skin factor created by drilling or completion fluids, filtercake sticking, and fines migration, among others
- completed intervals prior to squeeze treatments
- downhole flow control devices, such as sleeves and valves, to free stuck mechanisms.

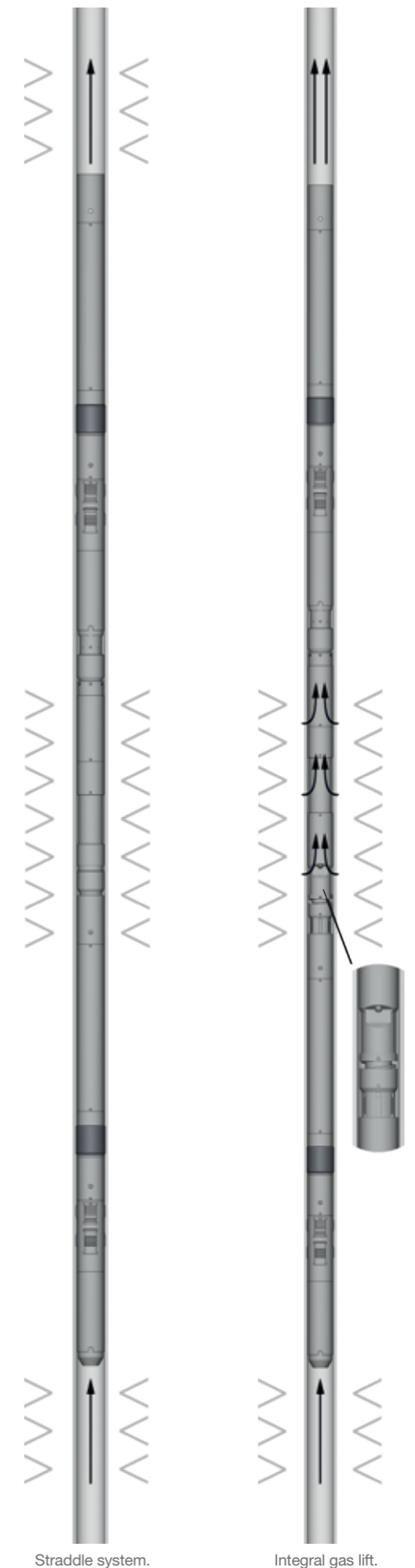

Straddle system.

Integral gas lift.

# Peak Performance

Confidence in a proven design

The safety-enhancing, cost-effective means for managing producing zones for operators worldwide.

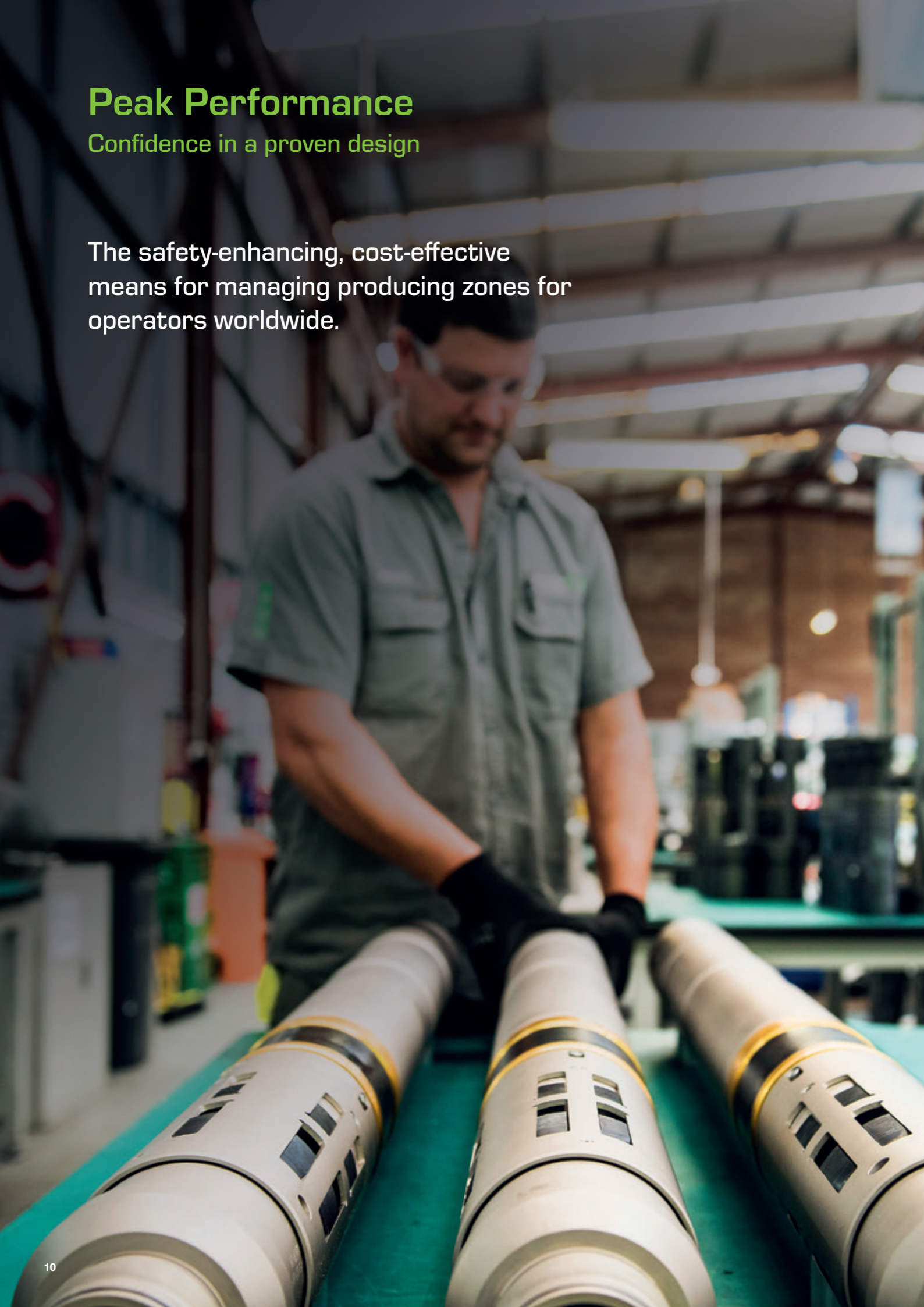

Since it was first developed in 2005, the SIM system has been successfully run by Peak Well Systems in highly varied applications, at locations around the world, more than 2,500 times—establishing Peak Well Systems as an industry leader in the design and provision of plug systems worldwide.

Successful deployment has been achieved in wide-ranging well conditions:

- highly deviated wells (72°)
- depths in excess of 14,000 ft
- high concentrations of CO<sub>2</sub> (>60%)
- high debris environments
- differential pressures up to 7,500 psi at 250 degF and 5,000 psi at 350 degF.

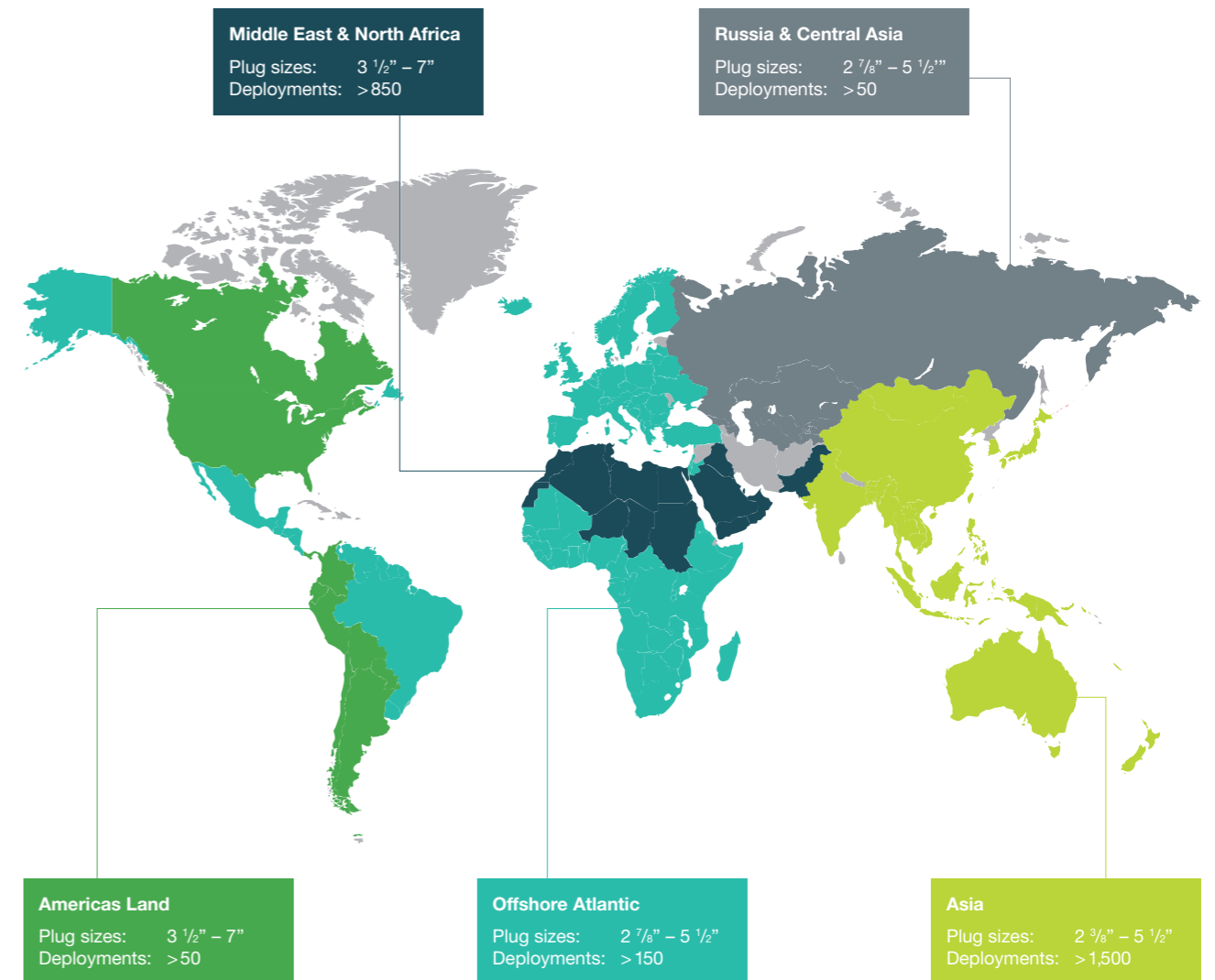

SIM System deployment as at April 2021

## SIM System for Flow Control

Well intervention, remediation, and well integrity operations all benefit from the ultimate flexibility available with the SIM system's wide range of superior, interchangeable modular flow control products.

Reduce well operating costs.  
Improve well performance.



Simple Safe Assured

# Products and Technical Specifications

All SIM system products are modular and have the following design features and capabilities:

- 100% mechanical
- safer than conventional methods—no pyrotechnics or special setting tools required
- simple to redress
- robust design
- interchangeable components resulting in reduced inventory
- recoverable from the wellbore using the industry-standard SIM system pulling tool for GS type fishing neck.

## SIM system running tool

Used to convey and selectively set all SIM system components, such as the SIM system retrievable and permanent bridge plugs, large-bore gauge hanger, and mechanical leak detection tool, at any chosen depth inside monobore type completions.

- Collet fingers—latch into SIM system devices
- Continuous radial indexing mechanism—selects the setting action
- Variable drag spring configuration—enables indexing in the range of casing sizes
- Serrated slips—provides a temporary anchor at the setting depth

### TECHNICAL INFORMATION

Nominal Tubing Size, in	Actual OD, in
2 3/8	1.810
2 7/8	2.200
3 1/2	2.720
4 1/2	3.600
5	4.050
5 1/2	4.450
7	5.650

Superior design that leverages the latest materials technology enables Peak Well Systems products to withstand the harshest environments.



## SIM system retrievable bridge plug

Used to provide a high-quality, reliable temporary barrier within the wellbore to enable isolation or remediation operations.

- Multiple setting options—mechanically on slickline, coiled tubing, or e-line
- Multiple equalizing assembly options—melon-, prong-, or pump open-type
- Debris catcher sub option for sealing plug version
- HPHT sealing element
- Sour service components to NACE MR0175 specifications
- Maximized throughbore to reduce downhole choke effect

### TECHNICAL INFORMATION

Nominal Tubing Size, in	Weight, lbm/ft	Plug OD, in	Plug ID, in	Length, <sup>†</sup> in	Pressure Differential, psi	Temperature Range, <sup>‡</sup> degF
2 3/8	4.6	1.81	0.314	54	7,500	104-350
	6.4	2.2	0.781	54	7,500	104-250
2 7/8	6.4	2.2	0.781	54	5,000	104-350
	12.7	2.52	0.781	54	5,000	104-250
3 1/2	9.2 - 10.2	2.72	1.259	61	5,000	104-350
	9.2 - 10.2	2.78	1.259	61	7,500	104-350
4 1/2	11.6 - 13.5	3.6	2	59	3,000	104-350
	11.6 - 15.1	3.65	2	59	5,000 <sup>‡</sup>	104-350
5	15 - 18	4.05	1.969	57	5,000 <sup>‡</sup>	104-350
5 1/2	17 - 20	4.53	2.362	61	5,000 <sup>‡</sup>	104-350
	23 - 26	4.45	2.3	61	5,000 <sup>‡</sup>	104-350
6 3/8	24	5.65	3.15	63	5,000	104-302

<sup>†</sup> Length inclusive of plug and prong-type equalizing assembly. Length may vary depending on deployment option.

<sup>‡</sup> Contact a Peak Well Systems representative for operations outside this temperature range.

<sup>‡</sup> Higher pressure rating available on request.

SIM system products are user friendly – easy to deploy as well as being field redressable.





# Products and Technical Specifications

## Large-bore gauge hanger

Used to carry data acquisition devices or as an anchor for instruments or equipment that require suspension in the wellbore.

- Extremely high load capacity—ideal for high stack-up weight applications
- Large throughbore for increased flow rate—minimized pressure drop across the hanger
- Compact design—improved handling in height-restricted rig-ups
- Lower connection options—flexibility in matching customer requirements

TECHNICAL INFORMATION				
Nominal Tubing Size, in	Tubing Weight, lbm/ft	Actual Gauge Hanger OD, in	Flow Area*, in <sup>2</sup>	GS to recover, in
2 3/8	6.4 - 7.8	2.200	2.00	2 1/2
3 1/2	9.2 - 10.2	2.700	3.54	3
4 1/2	10.5 - 15.1	3.600	6.95	4
5	15 - 20.3	4.050	7.61	4
5 1/2	17 - 23	4.450	9.60	5
7	23 - 32	5.650	15.10	6

\*Flow areas will vary slightly between different tubing weights for the same OD tubing.

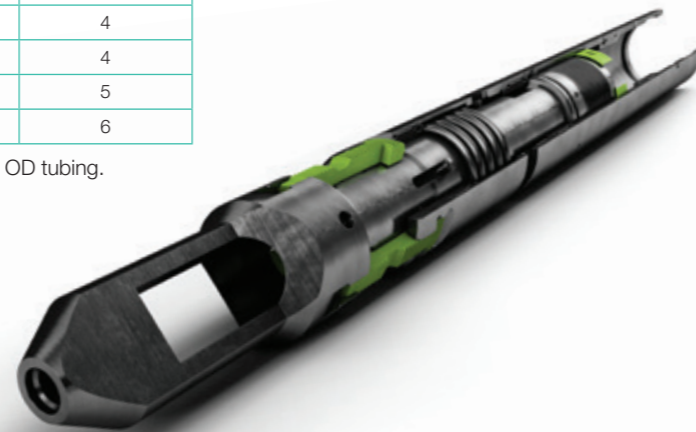

Products with higher functionality and interchangeability reduce inventory while delivering improved well performance.

## Leak detection tool

Used to create a temporary sealing barrier to enable conducting a surface pressure test to ascertain whether a potential leak path exists between the tubing and annulus.

- Can be reset multiple times in a single run in the well
- Reduces NPT by enabling multiple settings for quickly pinpointing a leak while minimizing wireline runs
- Equalizes the pressure across the element by employing an integral self-equalizing device before moving into the fully retracted position

TECHNICAL INFORMATION				
Nominal Tubing Size, in	Tubing Weight, lbm/ft	Actual OD, in	Pressure Rating, psi	Temperature Rating, degF
2 3/8	4.6	1.81	1,500	350
2 7/8	6.4 - 7.8	2.22	1,500	350
3 1/2	9.2 - 10.2	2.72	1,500	350
4 1/2	10.5 - 17.1	3.65	1,500	350



## SIM system permanent bridge plug

Used as a permanent barrier for achieving permanent zonal isolation and supporting plug and abandonment applications, with additional uses for zonal isolation for fracture stimulation and acidizing or cementing operations.

- Premium, cast iron construction
- ISO-14310, API 11D1 V3 certified barrier
- Rapid deployment on slickline, e-line, or coiled tubing
- Compact design for improved handling in height-restricted rig-ups

TECHNICAL INFORMATION					
Nominal Tubing Size, in	Weight, lbm/ft	Plug OD, in	Differential Pressure, psi	Temperature Range, degF	Setting - Approx. Shear Force, lbf
2 3/8	4.6	1.81	5,000	104-350	6,500
2 7/8	6.4	2.2	10,000	104-350	6,500
3 1/2	9.2 - 10.2	2.72	10,000	104-350	6,500
4 1/2	11.6 - 15.1	3.65	10,000	104-350	10,000

† Contact a Peak Well Systems representative for operations outside this temperature range.

‡ V3 accredited options available for 2 7/8-in, 3 1/2-in and 4 1/2-in plugs at 10,000 psi and 300 degF.

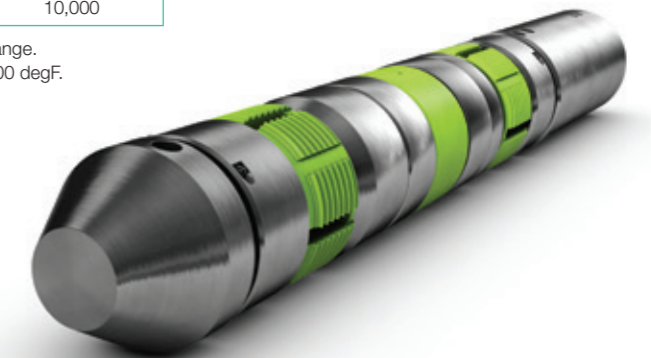

## FloWell formation damage removal technology

Used to induce a sudden pressure drawdown in a wellbore that causes a surge of fluid inflow along the perforation tunnel from the reservoir to improve well productivity by stimulating clean up of formation damage in the perforation tunnels, such as crushed zones, tenacious filtercake, and scale.

FloWell technology provides operators with a simple, reliable, low-cost, and robust way to surge perforations where desired:

- uses standard slickline tools and procedures to run and convey the system into the well
- requires no pyrotechnics, electronics, or pressure devices to activate the simple mechanical design of the tool
- can be deployed as a stackable system to treat zones of any length by stacking additional FloWell technology tools above a fixed anchor
- easily treats long zones with only a standard lubricator rig-up height, making FloWell technology ideal for remote platforms
- usually deployed for maximum effectiveness in conjunction with two SIM system plugs that form a seal at the top and bottom of the zone to be treated and ensure maximum drawdown at the sandface.

Peak Well Systems products have an unrivaled track record of dependability, even in the most challenging wells.

Peak Well Systems products consistently deliver the best long-term returns for customers.



Peak Well Systems also designs and manufactures tools within the SIM system product range that are regularly deployed as part of the downhole assembly. These are available in different sizes to suit the SIM system being deployed. Details and specifications for these products are available on request.

## SIM System in Action: Case Studies

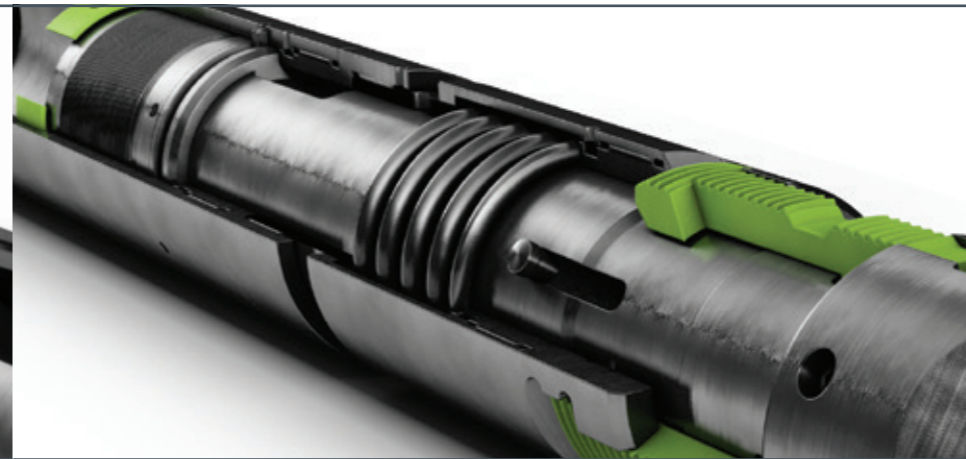
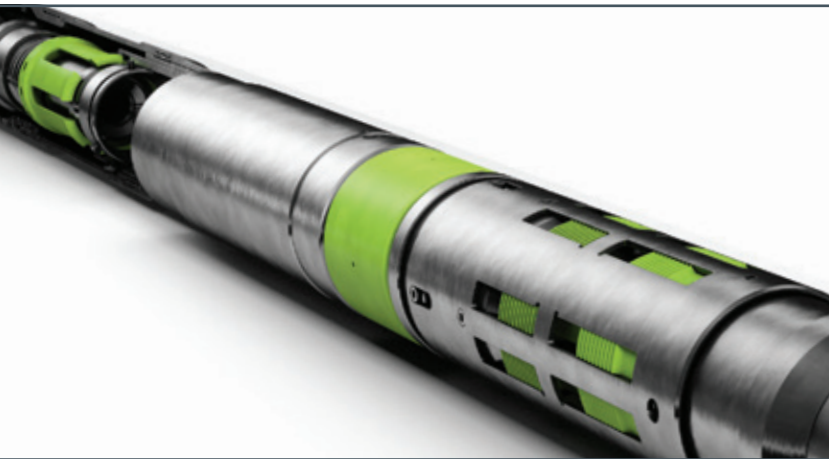

SIM system retrievable bridge plug and running tool.

### Independent oil company, North West Shelf, Australia

#### Well type

4½-in oil producer (57° deviation, 220 degF)

#### Deployment

4½-in SIM system retrievable bridge plug and running tool

#### The challenge

During plug and kill operations prior to a well workover, contingency steps were taken after several attempts to install a deep-set plug failed. The operator decided that a slickline-set, nippleless-type plug was required to provide the critical well barrier. It was suspected that the nipple profiles had been damaged by sand production and wire tracking from multiple slickline runs through the nipple profiles.

#### Considerations

The following key requirements and concerns were highlighted by the operator:

- debris expected after well kill and circulation
- high pick-up weights expected
- small setting window—adequate depth control required
- preference to use the onsite slickline crew
- e-line setting option required as a backup to slickline if excessive pick-up weights were encountered.

#### Summary

- Conducted SIM system retrievable bridge plug drift simulation.
- Correlated against nipple profile and set 4½-in retrievable bridge plug and prong.
- Successfully tested plug installation, which remained in the well for seven days.
- Performed bailing operations and recovered a significant amount of debris.
- Used the SIM system pulling tool to easily recover the bridge plug on the first attempt.

#### Value to customer

- Success was achieved with the first contingency option.
- All operations were performed safely and efficiently.
- SIM system plug successfully retrieved in high-debris environment.
- By opting for a 100% mechanical solution from Peak Well Systems, the operator mitigated the potential risks and expense of the operation.
- The short-term rental option preferred by the operator avoided further unnecessary expenditure.
- Workover operations progressed quickly and were completed successfully.

## SIM System in Action: Case Studies



### National oil company, Offshore Malaysia

#### Well type

5½-in oil producer (74° deviation, 250 to 330 degF)

#### Deployment

5½-in large-bore gauge hanger and SIM system running tool

#### The challenge

A programmed platform shutdown was scheduled, providing an ideal opportunity to conduct valuable data acquisition operations. Six wells across the field were strategically selected for pressure transient analysis.

#### Considerations

The campaign offered some difficult working conditions, both logistically and operationally. The following key requirements and concerns were highlighted by the operator:

- pinpoint data acquisition
- flow-through capability
- restricted rig-up height
- heightened safety concerns for the use of explosives and nitrogen
- temperature limits on two of the six wells
- limited persons on board (POB) capacity.

#### Summary

- Six 5½-in large-bore gauge hangers were set on slickline at different depths.
- Three gauges were connected to each gauge hanger.
- All gauge hangers remained successfully set for a duration of four weeks.
- All gauge hangers successfully recovered on standard GS.
- All data recovered from gauges.

#### Value to Customer

- Valuable data was acquired for pressure transient analysis.
- Nonproductive time was replaced with valuable operations.
- Personnel not exposed to explosives and nitrogen by conducting 100% mechanical operations.
- Significant cost savings were achieved while enabling greater insight to the field.

SIM system plugs do not require a positive profile to trip or set and use any point on the tubing wall to index.

## SIM System in Action: Case Studies

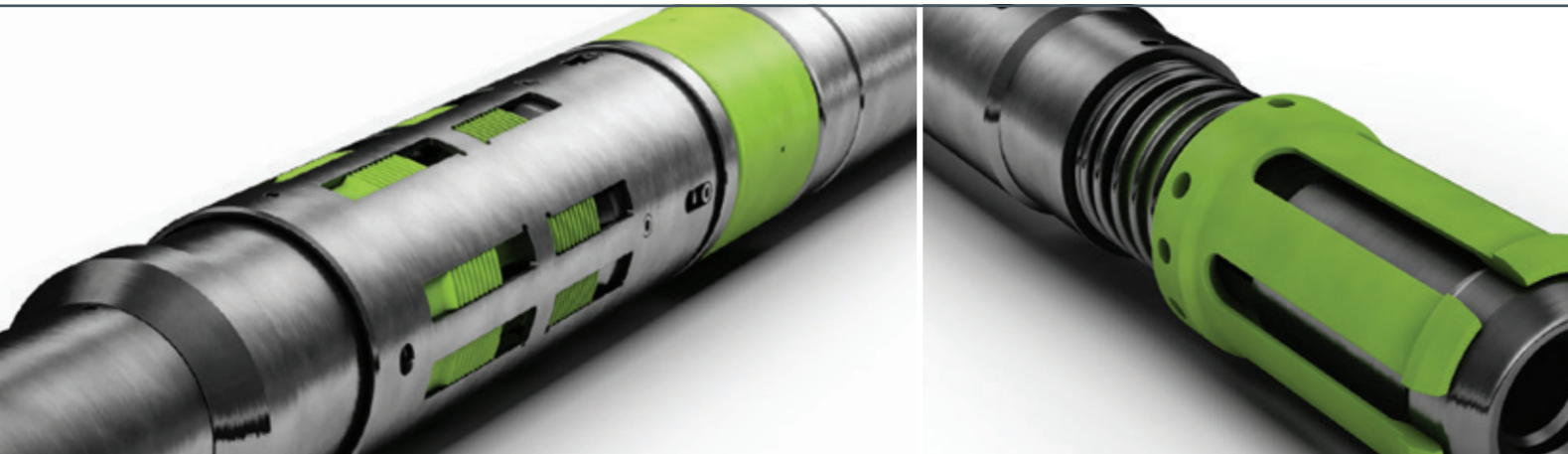

SIM system retrievable bridge plug and running tool.

### Major International oil company, Offshore West Africa

#### Well type

Various 4½-in oil producers  
(52° to– 69° deviation, 180 degF to 280 degF)

#### Deployment

4½-in system retrievable bridge plug and running tool

#### The challenge

When accessing high-value subsea wells with the latest-generation deepwater semi, the operator required a contingency option for the tubing test and packer setting during the completion phase of a multiple well development. To avoid unnecessary additional rig costs, Peak Well Systems SIM system retrievable bridge plug was chosen as a contingency mechanical barrier to be employed if the nipple profile within the completion was unusable.

#### Considerations

The following key conditions and requirements were highlighted by the operator:

- The SIM system retrievable bridge plug would be deployed only if the traditional lock was unable to be set. In this situation, the operational success of the retrievable bridge plug was vital.
- The plug must be able to pass and be cleanly recovered through a 3.688-in ID after setting.
- E-line setting was required as a secondary setting option.

#### Summary

The operator experienced major difficulties in accessing the nipple profile within the completion when attempting to set a locking device for a dedicated profile. Given these difficulties in passing the upper nipple to selectively set in the lower profile, the decision was made to use the SIM system retrievable bridge plug.

SIM system plugs do not require a positive profile to trip or set and use any point on the tubing wall to index. The slick nature of the SIM system retrievable bridge plug enables it to easily pass through a troublesome upper nipple with ease.

- The SIM system retrievable bridge plug easily passed the nipple profile and was set and tested successfully on the first attempt.
- Upon successful testing of the completion and surface equipment, the plug was recovered on the first attempt using the SIM system pulling tool.

#### Value to customer

- Significant rig costs were avoided by using the SIM system retrievable bridge plug.
- The SIM system plug was successfully deployed mechanically on slickline.
- All operations were performed safely and efficiently.
- The SIM system plug is now the primary well barrier option and the plug of choice for this customer.

The operator experienced issues with the same nipple during subsequent installation in other wells, so the SIM system retrievable bridge plug was used and performed flawlessly for each deployment. Due to the problems that occurred on these wells and the reliable success of the SIM system, all following completion programs were changed.

As a direct result of its reliability and performance, the SIM system retrievable bridge plug was specified by the operator as the primary deployment option, including future deployments in horizontal well sections with a tractor or stroker tool.

## Rentals

SIM system technologies are available for rental, with the following attendant benefits: immediate mobilization, reduced capex, increased flexibility, and options for short- and long-term rental packages.

At Peak Well Systems, we manufacture and maintain a large inventory of both standard and specialist tools, including SIM systems, fishing tools, and toolstrings for rental. Our rental tools are available for a wide range of tubing sizes and for all connection types, including compatibility with industry quick connections.

Rentals are supplied with technical data manuals, full certification documentation, and redress kits to ensure that our equipment is easily deployed and maintained. Should a customer require support on site, Peak Well Systems also has a team of specialist operational personnel who can work alongside your crew.

For all your rental enquiries, contact us at [info@peakwellsystems.com](mailto:info@peakwellsystems.com).



Peak Well Systems rental tools are available for a wide range of tubing sizes and for all connection types, including compatibility with industry quick connections.

## After Sales Support

Using Peak Well Systems products is about building partnerships with Peak and knowing that you are working with specialists who understand your challenges—before, during, and after deployment.

Customers can benefit from a range of after sales support options, including

- redress kits
- training
- onsite support from Peak Well Systems field specialists
- assembly animations.

## SIM System: Interchangeable Modular Components

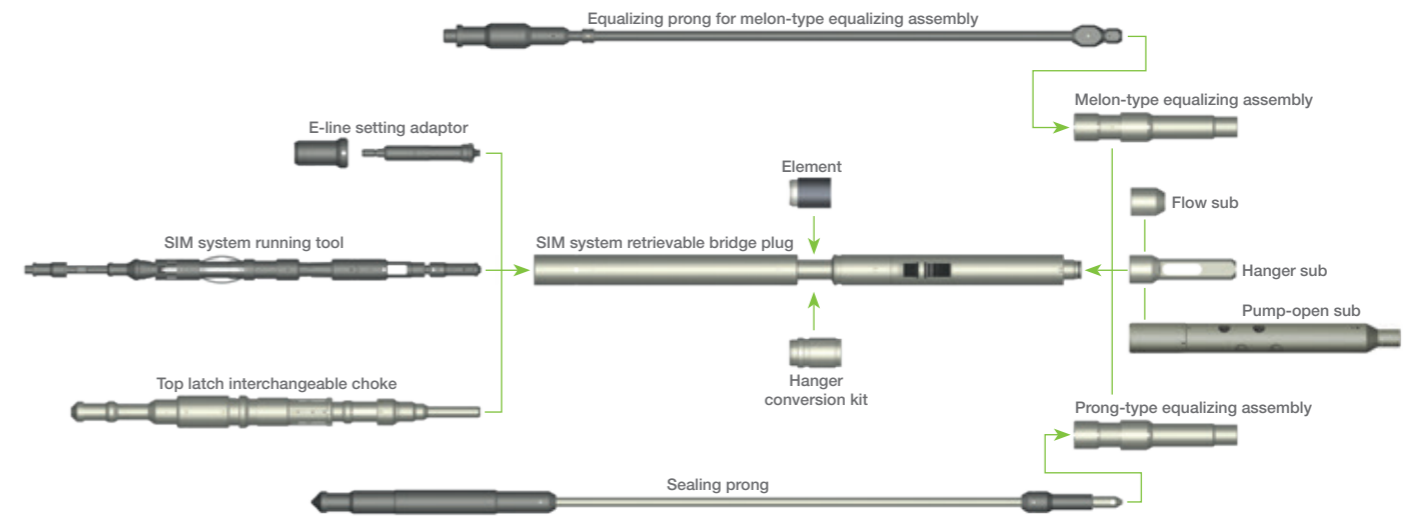

### SIM System Products

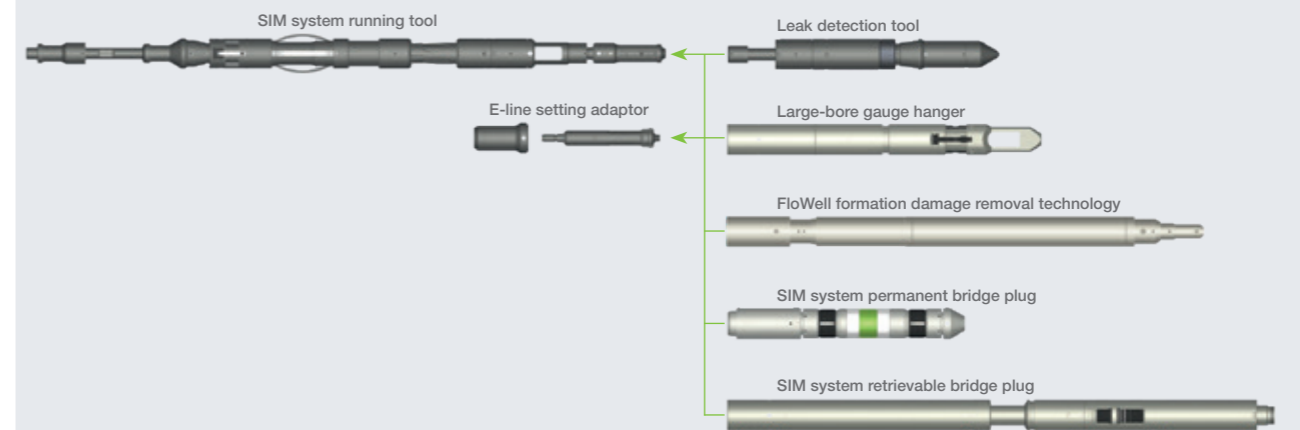

*For illustrative purposes only—not to scale.*

## About Peak Well Systems

Peak Well Systems, a Schlumberger company, is a leading specialist in the design and manufacture of advanced downhole tools for well intervention. We provide both operators and service companies around the world with an extensive range of innovative downhole products, expert field deployment and aftermarket support. Our aim is to reduce well operating costs and improve well performance for our customers.

Our product portfolio comprises of flow control systems, which are fast becoming the products of choice around the world, and premium well intervention tools for remedial well maintenance.

All Peak products are designed to be **Simple, Safe and Assured.**



Please scan QR  
code to view our  
Peak Technology  
TV Channel



[peakwellsystems.com](https://peakwellsystems.com)



\*Mark of SLB

© 2022 Peak Well Systems Pty Ltd. All rights reserved. This material and everything contained herein is the property of Peak Well Systems Pty Ltd and is prepared for information purposes only. Nothing contained within these materials shall be treated as a representation to be relied on by any person or an offer for sale or contract of any kind whatsoever. Any reproduction or distribution without the express written consent of Peak Well Systems Pty Ltd is strictly prohibited.