



Product Catalog

Simple Safe Assured

Index

Flow Control (Nippleless Products)

SIM Permanent Plug	6
SIM Retrievable Bridge Plug	7
SIMplus Retrievable Bridge Plug	8
SIMultra Retrievable Bridge Plug	9
SIM Running Tool	10
Boost Running Tool	11
PowerTool	12
Straddle System	13
Integral GLV Straddle	14
Peak Injection Valve	15
Peak Flow-Activated Safety Valve	16
E-Line Adaptor Kit	17
Melon-Type Equalizing Housing	18
Prong-Type Equalizing Housing	19
Melon-Type Equalizing Prong	20
Sealing Equalizing Prong	21
Pump Thru Check Valve	22
Pump Open Sub	23
Plug Pulling Tool	24

Flow Control (Nipple Products)

Standing Valve	26
FloSafe Lock Mandrel	27

Well Monitoring

Large Bore Gauge Hanger	29
Hi-Ex Gauge Hanger	30
eSetting Tool	31

Well Integrity

Leak Detection Tool	33
Tubing Alignment Tool	34

Production Enhancement

Top Latch Choke	36
FloWell	37

Fishing Systems

Full Radial Contact Gas Lift Valve (FRC GLV) Pulling Tool	39
HD FRC Pulling Tool (Jar Up to Shear)	40
HD FRC Pulling Tool (Jar Down to Shear)	41
HD Pulling System.	42
Double Jar Down Adaptor.	43
Double Jar Down FRC Pulling Tool	44
IN FRC Pulling Tool	45
Releasable Overshot	46
Non-Releasable Overshot	47
Releasable Spear	48
Non-Releasable Spear	49
Wireline Retrieval System	50
Wireline Centre Spear	51
Tapered Wire Retriever	52
Multi-Pin Running Tool	53
HD Dual Fish Neck Sub.	54
Multi-Action Top Sub (MATS)	55
Integral Bell Guide Bottom Housing	56
IB Orientation Indicator	57
Indexing Tool	58
Tubing End Locator	59
Pump Down Go-Devil	60
Sidewall Cutter	61
Peak Cutter	62
Peak eCutter	63
Heavy-Duty Peak eCutter	64
Peak Impression Block (PIB)	65

Premium Utility Toolstring

Compact Toolstring	67
Slickline Rope Socket	68
Slick and Swivel Rope Socket.	69
Braided Line Rope Socket	70
Braided Line Multi-Function Rope Socket	71
90 Degree Safe Connect (90DSC).	72
Accelerator	73
Knuckle Joint.	74
Swivel	75
Bearing Swivel.	76
Stem	77
Tungsten Stem	78

Pump Down Stem	79
Modular Drop Bar System (Go-Devil)	80
Peak Power Jar	81
Peak Hydraulic Jar	82
Hydraulic Calibration Sub	83
Spang Jar	84
Tubular Jar	85
Linear Jar	86
Crossover	87
Quick Connect (QC)	88
UHD Multi-Function Shear Pin Rope Socket	89
UHD Accelerator	90
UHD Knuckle Joint	91
UHD Power Jar	92
UHD Linear Jar	93
Safe Enclosed Pull Test Sub	94
Gauge Cutter	95
Blind Box	96
Combination Gauge Ring and Wire Scratcher	97
FlexiDrift	98
Bore-Sensing Drift	99
GS Pulling Tool	100
eMAT/GS Tool	101
Multi-Action Pulling (MAP) Tool	102

Wellbore Cleanup & Debris Removal

High Temperature/High Strength Magnet	104
Interchangeable Ring Broaching Tool	105
Pump Bailer	106
Hydrostatic Bailer	107
Drive Down Bailer	108
Dump Bailer	109
Radial Brush System	100
Torque-Action Debris Breaker	110

Roller Systems

Roller Stem	112
WellGlide	113
eWellGlide	114
Fluted Centralizer	115
Fluted Slip-Over Centralizer	116

Bespoke Products

Telescoping Space-Out Joint	118
WellGuard Hydraulic Hold-Open Tool	119



Flow Control (Nippleless Products)

Simple Safe Assured

SIM Permanent Plug

The SIM* permanent plug is a premium, cast iron bridge plug set 100% mechanically using the unique SIM running tool.

Using only a conventional slickline toolstring and without the need for explosives or hydraulic setting systems, the SIM permanent plug can be used in various applications such as zonal isolation in wells with multiple perforated zones; set as a barrier for plug and abandonment work; or used for zonal isolation during high pressure fracture stimulation; acidizing or cementing operations. The running OD is designed to pass most common completion nipple profiles and expand and set in its nominated tubing size and weight.

The SIM permanent plug is run and set using the same fully patented SIM system running tool that is also used to deploy the SIM retrievable bridge plug, Large Bore Gauge Hanger and Leak Detection Tool. Once the SIM running tool is landed off on depth, downward jarring is then required to set the SIM permanent plug. A check-pull is then applied to ensure the SIM permanent plug is fully set and securely anchored within the tubing. Subsequent upward jarring releases the SIM running tool from the SIM permanent plug and the SIM running tool can be removed from the well.

APPLICATIONS

- Permanent zonal isolation
- Plug and abandonment applications
- Zonal isolation for fracture stimulation, acidizing or cementing operations

FEATURES AND BENEFITS

- Can be set 100% mechanically anywhere in the tubing with the fully patented SIM running tool (UK Patent No: GB2432607 & GB2424237)
- Versatility: can also be set using any industry standard setting tools
- Safe: no pyrotechnics or special setting tools are required
- Cast iron construction: readily millable
- SIM running tool allows a check-pull to be taken against the set plug prior to shearing-off
- Cost-effective: rapid deployment with slickline spread requirement only - no need for electric line package
- Compact design makes utilization ideal in height restricted rig-ups

TECHNICAL INFORMATION

Nominal Tubing Size, in	Weight, lbm/ft	Plug OD, in	Differential Pressure, psi	Temperature Range, degF	Setting - Approx. Shear Force, lbf
2 $\frac{3}{8}$	4.6	1.81	5,000	104-350	6,500
2 $\frac{7}{8}$ ††	6.4	2.2	10,000	104-350	6,500
3 $\frac{1}{2}$ ††	9.2 - 10.2	2.72	10,000	104-350	6,500
4 $\frac{1}{2}$ ††	11.6 - 15.1	3.65	10,000	104-350	10,000

† Contact a Peak Well Systems representative for operations outside this temperature range.

†† V3 accredited options available for 2 $\frac{7}{8}$ -in, 3 $\frac{1}{2}$ -in and 4 $\frac{1}{2}$ -in plugs at 10,000 psi and 300 degF.

*Mark of Schlumberger

Product Code: SIM Permanent Plug / 370

info@peakwellsystems.com | peakwellsystems.com

© 2021 Peak Well Systems Pty Ltd. All rights reserved. Revision: 9 February 2021



▲ SIM Permanent Plug



SIMstandard retrievable bridge plug

The SIMstandard* retrievable bridge plug is an expandable seal-type barrier that can be set mechanically at any chosen depth inside monobore type completions or completions where existing production nipples are damaged.

The SIMstandard plug is conveyed using a conventional slickline toolstring. Once the setting depth is reached, the SIMstandard plug is selectively set by indexing and anchoring the running tool. Downward jarring activates the bidirectional SIMstandard plug slips and expands the sealing element. Upward jarring releases the running tool from the SIMstandard plug body.

For applications where setting depth is critical, the SIMstandard plug can be deployed and set on e-line using standard pyrotechnic setting tools.

The SIMstandard plug is recovered using a conventional GS pulling tool fitted with a Peak Multi-Action Top Sub (MATS) and pulling prong.

APPLICATIONS

- Retrievable bridge plug
- Straddle and lift straddle
- Lift (top latch interchangeable choke)
- Hanger as a gauge carrier for downhole tools

FEATURES AND BENEFITS

- Multiple setting options: mechanically on slickline, coiled tubing or e-line
- Simplistic design: simple to redress in the field
- Multiple equalizing assembly options: melon-, prong-, or pump open-type
- Uni- and bidirectional flow: ultimate flexibility to plug and divert flow
- Debris catcher sub option for sealing plug version
- High temperature/high pressure sealing element
- Sour service components to NACE MR0175 specifications
- Maximized throughbore to reduce down hole "choke" effect
- Interchangeable components for inventory reduction

TECHNICAL INFORMATION

Nominal Tubing Size, in	Weight, lbm/ft	Plug OD, in	Plug ID, in	Length, [†] in	Pressure Differential, psi	Temperature Range, ^{††} degF
2%	4.6	1.81	0.314	54	7,500	104-350
2%	6.4	2.2	0.781	54	7,500	104-250
	6.4	2.2	0.781	54	5,000	104-350
3½	12.7	2.52	0.781	54	5,000	104-250
	9.2 - 10.2	2.72	1.259	61	5,000	104-350
	9.2 - 10.2	2.78	1.259	61	7,500	104-350
4½	11.6 - 13.5	3.6	2	59	3,000	104-350
	11.6 - 15.1	3.65	2	59	5,000 [‡]	104-350
5	15 - 18	4.05	1.969	57	5,000 [‡]	104-350
5½	17 - 20	4.53	2.362	61	5,000 [‡]	104-350
	23 - 26	4.45	2.3	61	5,000 [‡]	104-350
6%	24	5.65	3.15	63	5,000	104-302

[†] Length inclusive of plug and prong-type equalizing assembly. Length may vary depending on deployment option.

^{††} Contact a Peak Well Systems representative for operations outside this temperature range.

[‡] Higher pressure rating available on request.

*Mark of Schlumberger

Product Code: SIMstandard / 351

info@peakwellsystems.com | peakwellsystems.com

© 2021 Peak Well Systems Pty Ltd. All rights reserved. Revision: 14th September 2021



▲
SIMstandard retrievable bridge plug
UK Patent : GB2432607 & GB2424237
US Patent : US7,654,334B2
Australia Patent : 2004287895
Patent Pending - Malaysia and Thailand

peak
WELL SYSTEMS

SIMplus Retrievable Bridge Plug

The SIMplus* Retrievable Bridge Plug is an expandable barrier that creates a reliable and high performance downhole seal in fluid and temperature cycling environments. It forms part of Peak's SIMplus range of ISO 14310:2008 validation grade V3 products.

The SIMplus Retrievable Bridge Plug can be mechanically set at any chosen depth within the completion tubing or liner without the requirement for a nipple profile.

Available in all industry sizes from 2½ in up to the largest 7-in size, it can be deployed by all conventional conveyancing methods and, with its advanced setting mechanism, is the only mechanically set V3 rated plug available, creating unrivalled operational flexibility and confidence.

The large internal diameter (ID) of the SIMplus Retrievable Bridge Plug makes this sealing system ideal for modular straddle applications, leak detection and where flow is restricted, offering excellent flexibility, high assurance and conformance to the most stringent of well barrier criteria. The SIMplus Retrievable Bridge Plug is recovered using a conventional GS Pulling Tool fitted with industry standard Peak Multi-Action Top Sub (MATS) and Pulling Prong.

Quality controls (level 3) for the storage, maintenance and documentation for performance tracking and traceability are incorporated into the development of all SIMplus products.

APPLICATIONS

- Well suspension during completion, workover and well maintenance
- Zonal isolation for leaks, water/gas shut-off or stimulation
- Straddle for gas-lift
- Downhole choke and inflow control
- Packer setting and completion pressure tests
- Suspension of downhole gauges

FEATURES AND BENEFITS

- ISO 14310:2008 V3 accreditation
- Simple to redress in the field minimizing NPT
- Multiple setting options: mechanically on slickline, eline, coiled tubing, drill pipe or tractor
- Debris tolerant design to limit ingress
- Multiple equalizing assembly options (melon-, prong-, or pump open-type)
- Ultimate flexibility to plug and divert flow using uni- and bidirectional flow
- Operational assurance from high temperature/high pressure sealing element
- Sour service components to NACE MR0175 specifications

TECHNICAL INFORMATION

Nominal Tubing Size, in	Weight, lbm/ft	Plug OD, in	Plug ID, in	Length, in	ISO 14310:2008 V3 Qualification		
					Pressure Differential, psi	Temperature Range,† degF	Max. Setting ID, in
2½	6.4	2.2	0.781	54	7,500	104-300	2.493
3½	9.2 - 10.2	2.72	1.259	61	5,000	104-300	3.046
4½	11.6 - 15.1	3.65	2	59	5,000	104-300	4.03
5½	15.5	4.53	2.362	61	5,000	104-300	5.03
	17 - 20	4.53	2.362	61	5,000	104-300	4.975
	23	4.45	2.362	61	5,000	104-300	4.765
7	29 - 32	5.72	2.362 ^{††}	63	5,000	104-300	6.293
	23 - 26	5.84	2.362 ^{††}	63	5,000	104-300	6.465

† Contact a Peak Well Systems representative for operations outside this temperature range.

†† 3.15-in ID available on request

*Mark of Schlumberger

Product Code: SIMplus Retrievable Bridge Plug / 351

info@peakwellsystems.com | peakwellsystems.com

© 2020 Peak Well Systems Pty Ltd. All rights reserved. Revision: 10th February 2020



▲
SIMplus Retrievable Bridge Plug
UK Patent : GB2432607 & GB2424237
US Patent : US7,654,334B2
Australia Patent : 2004287895
Patent Pending - Malaysia and Thailand

peak
WELL SYSTEMS

SIMultra retrievable bridge plug

The SIMultra* retrievable bridge plug blends the breakthrough hybrid SIMultra seal technology with Peak's trusted plug architecture to create a well barrier providing the ultimate in reliability and retrievability whilst maintaining the highest performance specification.

Available for industry standard tubulars ranging from 4 ½ to 7 in, SIMultra plugs are fully certified to the highest ISO 14310 (API 11D1) V0 grade standard. SIMultra plugs have the smallest running diameter in their class, provide the highest available seal integrity, and retract to smaller than their original diameter thereby ensuring reliable deployment and recovery every time.

The SIMultra plug is set and retrieved using Peak's modular, nonexplosive, PowerTool setting system which enables deployment in vertical and horizontal wells using all conventional conveyance methods. When combined with the SIMultra plug, the PowerTool system provides unrivalled operational flexibility and confidence.

ISO certified quality control is incorporated into the development, manufacture, storage and maintenance of all SIMultra products and all SIMultra plugs are manufactured to Quality Grade Q3.

APPLICATIONS

- **Temporary Suspension:** Reliable recovery and the largest running clearances in the industry make SIMultra plugs ideal for short- and medium-term well suspension whilst providing the highest V0 grade well control barrier
- **Abandonment:** The unique hybrid metal-elastomer seal provides a full metal contact with the wellbore ensuring complete encapsulation of the seal system and is ideal for long-term, life-of-well, deployment or abandonment
- **Flow Control:** The SIMultra system maintains a large through-bore and a flow path up to 50% larger than competitor systems making it ideal for flow control applications when combined with chokes or shut-in tools

FEATURES AND BENEFITS

- Fully certified to ISO 14310:2008 grade V0
- Simple to redress in the field minimizing NPT
- Multiple setting options: slickline, e-line, coiled tubing, drillpipe or tractor
- Bidirectional, high-expansion, high-load slips ensures secure setting
- Independent positive retention of slips and seal ensures reliable retraction
- Fully sequenced operation eliminates plug movement during setting
- High-integrity one-piece mandrel eliminates potential leak paths
- Compatible with SIM* sealing integrity management system junk catchers and equalizing accessories
- Sour service components to NACE MR0175 specifications

TECHNICAL INFORMATION

Nominal Tubing, in	Weight Range, lbm/ft	Plug OD, in	Plug ID, in	Length, in	ISO 14310:2008 V0 Qualification		Setting Tool OD, in
					Pressure differential, psi	Max Temp †, degF	
4 ½	11.6 - 18.8	3.375	1.375	91.5	10,000	350	3.375
5	23.2	3.500	1.375	91.5	10,000	350	3.375
5 ½	17 - 26	4.100	1.375††	98.6	10,000	350	4.100
7	29 - 32	5.470	3.375	92.5	10,000	350	5.470

† 400 degF extreme sour service available on request.

†† Larger plug ID available on request.

*Mark of SLB.

Product Code: SIMultra / 851

info@peakwellsystems.com | peakwellsystems.com

© 2023 Peak Well Systems Pty Ltd. All rights reserved. Revision: 3 January 2023

This material and everything contained herein is the property of Peak Well Systems Pty Ltd and is prepared for information purposes only. Nothing contained within these materials shall be treated as a representation to be relied on by any person or an offer for sale or contract of any kind whatsoever. Any reproduction or distribution without the express written consent of Peak Well Systems Pty Ltd is strictly prohibited. The product to which this datasheet pertains is proprietary technology owned by Peak Well Systems Pty Ltd and patented under numbers referenced herein.



▲ SIMultra seal technology



▲ SIMultra retrievable bridge plug



SIM Running Tool

The SIM* System is a series of mechanically interchangeable components designed to provide a range of applications for the purpose of well integrity and production management.

The fully patented SIM Running Tool is used to convey and selectively set these components at any chosen depth inside monobore type completions.

The SIM Running Tool is made up to the selected device at surface and conveyed into the well on a conventional slickline toolstring. A radial indexing mechanism activates a set of slips to anchor the Running Tool to the tubing wall at any desired setting depth. The device is then simply set by downward jarring. An overpull is applied to confirm the deployed component is fully set. Once set in place the SIM Running Tool is released from the device by upwards jarring.

APPLICATIONS

Used for selectively setting:

- SIM Retrievable Bridge Plugs
- Mechanical Leak Detection Tool
- Large Bore Gauge Hanger
- SIM Permanent Plug

FEATURES AND BENEFITS

- Continuous radial indexing mechanism
- Variable drag Spring configurations
- 100% mechanical - simple to redress
- Robust design

TECHNICAL INFORMATION

Nominal Tubing Size, in	Actual OD, in
2 3/8	1.810
2 7/8	2.200
3 1/2	2.720
4 1/2	3.600
5	4.050
5 1/2	4.450
7	5.650



▲ UK Patent : GB2432607 & GB2424237
 US Patent : US7,654,334B2
 Australia : 2004287895
 Patent Pending - Malaysia and Thailand

*Mark of Schlumberger

Product Code: SIM Running Tool / 350

info@peakwellsystems.com | peakwellsystems.com

© 2017 Peak Well Systems Pty Ltd. All rights reserved. Revision: 3rd April 2013



Boost Running Tool

The Boost Running Tool, is used to convey and selectively set SIM* and SIMplus* products at any chosen depth by mechanical slickline.

The Boost Running Tool is enhanced by an in-built hydraulic chamber during downward jarring creating the high forces required to set large bore SIM and SIMplus Retrievable Bridge Plugs or other devices at extreme depth and deviation.

The Boost Running Tool is made up to the selected device at surface and conveyed into the well on a conventional slickline toolstring. Peak's field proven radial indexing system activates a set of slips to anchor the Boost Running Tool to the tubing wall at any desired setting depth. Like the standard running tool the Boost Running Tool is simply activated by downward jarring which primes the hydraulic boost chamber creating an augmented high force output to ensure the device is fully set. The Boost Running Tool automatically shears when the required setting force output is achieved, allowing the tool to be released from the device.

The setting force is applied via the hydraulic chamber to assist in amplifying the jarring force via engagement of a different piston ratio (approx. 2.5:1) after initial set of the slips has been achieved. The hydraulic boost system is fully enclosed and does not rely on hydrostatic pressure to produce the required force output.

APPLICATIONS

Used for selectively setting:

- SIM and SIMplus Retrievable Bridge Plugs
- Large Bore Gauge Hanger
- SIM Permanent Plugs

FEATURES AND BENEFITS

- Fully field redressable
- Robust design with continuous radial indexing mechanism
- 100% mechanical with hydraulic boost to amplify jarring force
- High force output by mechanical slickline
- Suitable for setting large bore retrievable bridge plugs in remote locations where no e-line is available
- Incorporates Peak's field proven mechanical indexing system for accurate depth selection and setting

TECHNICAL INFORMATION

	Tool OD, in	Tool Length, in	Tool Weight, kg	Op. Temp, degF	Recommended Oil	Force Output, lbf	No. jars to set
5½	4.449	90.99	50.63	302	ATF	25,000	10 - 20
7	5.650	89.95	79.43	302	ATF	35,000	30 - 40

*Mark of Schlumberger

Product Code: Boost Running Tool / 364

info@peakwellsystems.com | peakwellsystems.com

© 2017 Peak Well Systems Pty Ltd. All rights reserved. Revision: 27th October 2014



peak 
WELL SYSTEMS

Peak PowerTool

The Peak PowerTool is a versatile modular downhole power system capable of deployment on all conveyance systems.

The modular Peak PowerTool can accommodate a wide range of different applications and conveyance methods through various configurations.

The short module length and nonexplosive drive ensure rapid deployment in the field.

During slickline operations, the PowerTool's intelligent Decision Module uses measurements of pressure, temperature, and tool movement to provide reliable downhole control.

The PowerTool is designed for versatility and can be operated in both forward and reverse modes. Different actuator modules address a wide range of applications with setting forces up to 180,000 lbf.

A unique feature of the PowerTool is the contingency to release from a plug or other downhole tool if they become stuck downhole. This feature enables the PowerTool to be reliably retrieved if problems occur and to reengage with the stuck equipment for subsequent recovery.

APPLICATIONS

- Setting and retrieval of permanent and retrievable plugs and packers
- Actuation of downhole sliding sleeves and side-doors
- Actuation of mechanical tubing punchers and cutters

FEATURES AND BENEFITS

- Nonexplosive drive system
- Configurable for a wide range of applications and force requirements
- Modular for deployment on slickline, e-line, coiled tubing, drillpipe and tractor
- Setting is independent of hydrostatic pressure
- Long stroke with reversible stroke direction
- Integrated contingency mechanical release system

TECHNICAL INFORMATION

PowerTool Drive	Temperature, degF [degC]	Hydrostatic Pressure, psi [MPa]	Drive OD, in	Make-Up Length, ft [m]
Slickline	329 [165]	10,000 [68.9]	3.375	10.62 [3.24]
E-Line	347 [175]			5.24 [1.6]
Coiled Tubing or Drillpipe	347 [175]			3.12 [0.95]

PowerTool Actuator Nominal Size, in	Temp., degF [degC]	Hydrostatic Pressure, psi [MPa]††	Actuator OD, in	Stroke Length, in [mm]	Approx. Force, lbf [N]		Make-Up Length [†] , ft [m]	
					Two Actuator Pistons	Three Actuator Pistons	Two Actuator Pistons	Three Actuator Pistons
4 ½	347 [175]	10,000 [68.9]	3.375	12 [304.8]	100,000 [‡]	4.79 [1.46]	150,000	6.51 [1.98]
5 ½			4.100		180,000	4.92 [1.50]	275,000	6.68 [2.04]
7			4.100					

† For CT/DP, length depends on force required and pressure delivery

‡ Lower force with shorter make-up length available on request

†† Higher hydrostatic 12,000 psi available on request

Product Code: Peak PowerTool / 810

info@peakwellsystems.com | peakwellsystems.com

© 2021 Peak Well Systems Pty Ltd. All rights reserved. Revision: 11 October 2021



Straddle System

The SIM* and SIMplus* Plug Systems can be fitted with straddle tubes between an upper and lower packer to provide isolation across the straddled zone. There is no requirement for a different device – all SIM and SIMplus System applications use the same modular base components.

The Straddle System has a unique selective latch mechanism on each straddle connector to allow the tubes to be recovered one at a time should the straddle need to be retrieved. This can be critical for safety purposes when trying to recover the straddle section back into the lubricator. If the recovered straddle system is longer than expected because more than one straddle tube has been recovered, it may not be possible to function the x-tree valves thus creating a safety hazard.

APPLICATIONS

- To isolate water zones
- To isolate unwanted gas flow
- To isolate a hole in tubing
- To isolate a leaking device within the tubing - SPM, SSD etc
- Can be deployed prior to setting a permanent patch in the well - this would allow the effect of setting the patch to be determined

FEATURES AND BENEFITS

- Can be fully slickline installed and recovered
- Stackable straddle tubes with selective release mechanism
- Straddle tubes available in 5-ft and 10-ft length sections as standard (other lengths available upon request)
- Maximized flow area
- Quick and easy redress
- 5,000 psi pressure rating; 350 degF temperature rating
- Available with integral gas lift device (GLV Straddle System)

TECHNICAL INFORMATION

Nominal Tubing Size, in	Weight, lbm/ft	OD, in	Pressure Rating, psi	Temperature Range, [†] degF	Min. ID, ^{††} in
2 7/8	6.4	2.22	5,000	104-350	0.781
	6.4	2.22	7,500	104-250	0.781
3 1/2	9.2 - 10.2	2.72	5,000 [‡]	104-350	1.259
4 1/2	11.6 - 15.1	3.6/3.65	5,000 [‡]	104-350	2
5	15 - 18	4.05	5,000 [‡]	104-350	1.969
5 1/2	15.5 - 20	4.53	5,000 [‡]	104-350	2.362
7	23 - 32	5.72/5.84	5,000 [‡]	104-350	3.15

[†] Contact a Peak Well Systems representative for operations outside this temperature range.

^{††} Minimum IDs for standard system are listed. Actual straddle system minimum IDs may vary depending on application.

[‡] Higher pressure rating available on request.

*Mark of Schlumberger

Product Code: Straddle System / 354

info@peakwellsystems.com | peakwellsystems.com

© 2019 Peak Well Systems Pty Ltd. All rights reserved. Revision: 27th November 2019



▲ SIM Straddle System

peak 
WELL SYSTEMS

Integral Gas Lift Valve Straddle

The Integral Gas Lift Valve (GLV) Straddle incorporates a gas lift choke sub/connector that is run within Peak's Straddle System to provide controlled gas flow from the gas zone behind the straddled zone.

The choke can be resized by recovering the upper straddle tube, if required. The GLV can simply be changed out by pulling the top plug complete with the gas lift mandrel assembly. The GLV is then swapped. The top plug, complete with gas lift mandrel assembly is then set into the straddle seal receptacle fish neck and tested.

APPLICATIONS

- To provide controlled gas flow from straddled gas zones

FEATURES AND BENEFITS

- Incorporated within the SIM* and SIMplus* Straddle System
- Can be fully slickline installed and recovered
- Stackable straddle tubes with selective release mechanism
- Straddle tubes available in 5-ft, 7½-ft, and 10-ft lengths
- Allows the user to install the gas lift valve deep in the well, at the sand face
- Helps prevent the need for an expensive workover
- Slip design helps ensure stresses exerted on tubing are evenly distributed thus preventing damage
- Allows extension of existing gas lift to depths previously unavailable
- Allows reinstatement of controlled gas lift in wells where existing systems have failed
- Cost-effective solution for installation of controlled gas lift in wells with depleted reservoirs

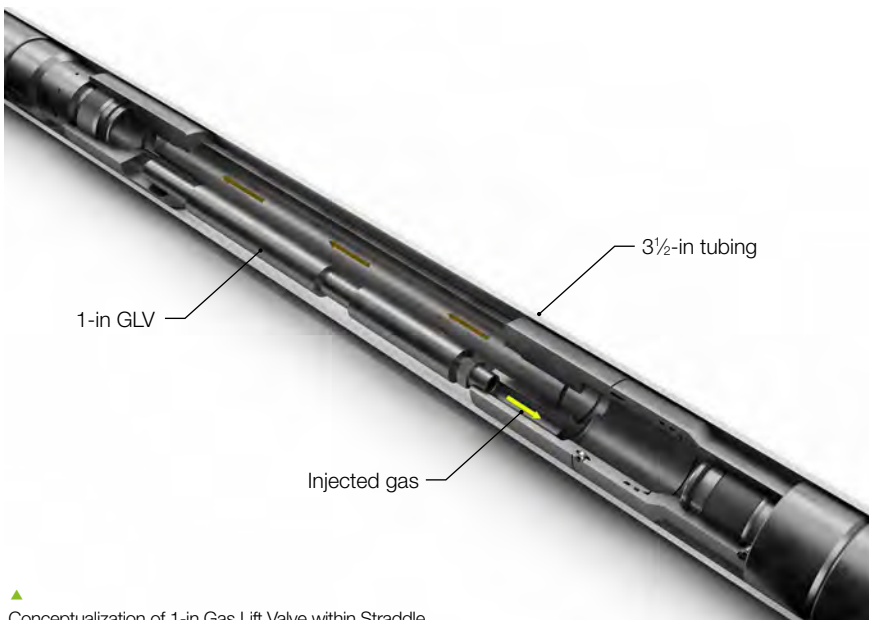

▲ Conceptualization of 1-in Gas Lift Valve within Straddle

*Mark of Schlumberger

Product Code: Integral Gas Lift Valve Straddle / 357

info@peakwellsystems.com | peakwellsystems.com

© 2020 Peak Well Systems Pty Ltd. All rights reserved. Revision: 21st January 2020

peak 
WELL SYSTEMS

Peak Injection Valve

The Peak Injection Valve is a normally closed flapper-type valve. It is used to reinject produced fluids or to inject fluids for EOR.

Fluids are injected from surface through the Peak Injection Valve, opening the flapper which is then held open by a sleeve to prevent the flapper 'floating' due to pump pulsations.

The Peak Injection Valve has the facility for a carbide choke to be inserted, if required, to control the injection rate and hold-open differential.

The Peak Injection Valve can be suspended below industry standard lock mandrels or below any of the Peak SIM* system retrievable bridge plugs. This versatility allows the valve to be set at any required depth and in a wide range of operational situations.

APPLICATIONS

- Injection of fluids for EOR
- Reinjection of produced fluids

FEATURES AND BENEFITS

- Integral equalizing device equalizes pressure across the valve allowing multi-cycle opening without the need to pull and/or redress any part
- Industry standard metal-to-metal flapper seal
- Chokes can be inserted to control flow rate and hold-open actuation pressure
- Standard type packing barrel with Chevron seals isolates the Injection Valve in the tubing
- Straight through flow path within the valve bore maintains laminar flow and reduces tubing erosion

TECHNICAL INFORMATION

Nominal Tubing Size, in	Max. Tool OD, in	Min. ID (no choke), in	Pressure Rating, psi [kPa]
2 $\frac{7}{8}$	2.295	0.906	5,000 [34,474]
3 $\frac{1}{2}$	2.800	1.500	5,000 [34,474]



▲
Peak Injection Valve

peak 
WELL SYSTEMS

*Mark of Schlumberger

Product Code: Peak Injection Valve / 510

info@peakwellsystems.com | peakwellsystems.com

© 2020 Peak Well Systems Pty Ltd. All rights reserved. Revision: 28th July 2020

Flow-Activated Safety Valve

The Peak Flow-Activated Safety Valve (FASV) is a cost effective, insert safety device that can be run below any suitable lock mandrel or nippleless SIM* retrievable bridge plug.

The Peak FASV is deployed in the flapper open position and will close as the velocity of produced fluids increases across the internal choke. Chokes are supplied in 1/64-in increments to suit customer requirements. The Peak FASV has an integral equalizing device to allow for quicker and safer equalization across the closed flapper when no pump/pressure facility is available at the wellhead.

APPLICATIONS

- Used when surface communication is no longer available between the surface control panel and the tubing retrievable surface controlled subsurface safety valve (TRSCSSV).
- High flow-rate wells.
- Shallow or deep-set applications.

FEATURES AND BENEFITS

- Simple and cost effective: carbide choke design
- Versatile: can be run below any lock mandrel or suitable nippleless bridge plug.
- Safer: Nitrogen gas not required
- Robust: all surfaces are treated to 55 RC to resist erosion
- Effective: through-conduct flow path results in less turbulence
- Reliable: features a metal-to-metal flapper seal and integral equalizing device

TECHNICAL INFORMATION

Nominal tubing size, in	Max. Tool OD, in	Min. Tool ID (no choke), in	Length, in [m]	Pressure Rating, psi [kPa]
2 7/8	2.295	1.000	38.2 [0.97]	5,000 [34,474]
3 1/2	2.800	1.500	40.9 [1.04]	5,000 [34,474]
4 1/2	3.800	2.000	46.3 [1.18]	5,000 [34,474]

Note: can be provided with threaded connections to suit most applications.



▲ Peak Flow-Activated Safety Valve.

An equalizing prong can be run to equalize across the flapper in the event no pump/pressure facility is available.

*Mark of SLB

Product Code: Flow-Activated Safety Valve / 500

info@peakwellsystems.com | peakwellsystems.com

© 2023 Peak Well Systems Pty Ltd. All rights reserved. Revision: 30 January 2023

peak 
WELL SYSTEMS

E-Line Adaptor Kit

The e-line adaptor kit provides an interface between Peak's SIM* and SIMplus* system products that are mechanically set, and Schlumberger or third-party setting tools where non-mechanical technologies are required.

e-line adaptors may be required where depth correlation is critical. Deviation prevents slickline setting so powered devices (such as tractors) can be used to transport the plug to target depth.

APPLICATIONS

- Where depth control is critical
- For high deviation deployment

FEATURES AND BENEFITS

- Easily retrofitted to industry standard setting tools
- Shear screw/disc release mechanism

TECHNICAL INFORMATION

Nominal Tubing Size, in	Actual OD, in
2 3/8	1.810
2 7/8	2.200
3 1/2	2.720
4 1/2	3.600
5	4.050
5 1/2	4.450
6 5/8	5.650
7	5.650

Note: The e-line adapter kit can be supplied to suit all Schlumberger or third-party setting options. Contact a Peak Well Systems' representative for more information.



▲
e-line adapter kit

*Mark of Schlumberger

Product Code: E-Line Adaptor Kit / 356

info@peakwellsystems.com | peakwellsystems.com

© 2017 Peak Well Systems Pty Ltd. All rights reserved. Revision: 9 November 2020



Melon-Type Equalizing Housing

The Melon-Type Equalizing Housing is a commonly used method of achieving pressure equalization across a set plug. It incorporates a simple equalizing melon that is run “on-seat” in the sealed position and allows the SIM* or SIMplus* Plug to be conveyed in a single run.

Recovery of the Melon-Type Equalizing Housing requires two-runs-to-pull. The Melon-Type Equalizing Prong is run prior to the MATS/GS pulling prong to equalize pressure across the plug and allow safe recovery. Jarring down on the equalizing prong will move the melon “off-seat” allowing pressure across the plug to equalize.

APPLICATIONS

- To provide a Melon-Type equalizing option for the SIM and SIMplus Plug
- For use with a Peak SIM Plug or SIMplus Plug when a single run application is required

FEATURES AND BENEFITS

- Threaded equalizing port options to control the rate of equalization
- Associated equalizing prong incorporates tell-tale feature to ensure melon has moved into the “off-seat” position
- Sour service components to NACE MR0175
- All components ENP treated to prevent thread galling and corrosion
- Simplistic design with minimal components
- Sucker rod box thread in equalizing assembly bottom sub to convey downhole gauges or to provide a connection for roller options in high-angle, deviated wells
- Robust design

TECHNICAL INFORMATION

To Suit Plug, in	Standard Length, in	Minimum ID, in
2 3/8*		
2 7/8	13.90	0.709
3 1/2	12.20	1.142
4 1/2	12.60	1.870
5	12.60	1.870
5 1/2	16.18	1.870

*Does not include the melon equalizing option.



▲ SIM Plug with Melon-Type Equalizing Housing

▲ Melon-Type Equalizing Prong

*Mark of Schlumberger

Product Code: Melon-Type Equalizing Housing / 352

info@peakwellsystems.com | peakwellsystems.com

© 2017 Peak Well Systems Pty Ltd. All rights reserved. Revision: 20th August 2014



Prong-Type Equalizing Housing

(Used with the SIM* or SIMplus* Plug, Sealing/Equalizing Prong)

The Prong-Type Equalizing Housing is the most commonly used method of sealing and equalizing across the set plug downhole and is recommended for use where there may be debris present. It incorporates a simple seal bore receptacle which is designed to accept a secondary run sealing prong.

After the Prong-Type Equalizing Housing has been set, the sealing prong is run on a standard JD- or SB-type pulling tool to create the sealing plug. To allow safe recovery of the plug, the sealing prong is recovered with a standard JD- or SB-type pulling tool to ensure equalization has taken place prior to the MATS/GS pulling prong being deployed to recover the plug.

APPLICATIONS

- To provide a prong-type equalizing option for the Peak SIM and SIMplus Plug
- Ideal for use with the Peak SIM and SIMplus Plug when debris may be present in the well

FEATURES AND BENEFITS

- Threaded equalizing port options to control the rate of equalization
- Associated equalizing prong incorporates shearable centralizer and seal protector feature to ensure seals are protected whilst running in the well and that the prong is guided into the SIM Plug correctly
- Sour service components to NACE MR0175
- All components ENP treated to prevent thread galling and corrosion
- Simplistic design with minimal components
- Robust design
- Sucker rod box thread in equalizing assembly bottom sub to convey downhole gauges or to provide a connection for roller options in high-angle, deviated wells

TECHNICAL INFORMATION

To Suit Plug, in	Standard Length of Housing, in
2 $\frac{3}{8}$	11.60
2 $\frac{7}{8}$	14.80
3 $\frac{1}{2}$	14.82
4 $\frac{1}{2}$	14.82
5	14.82
5 $\frac{1}{2}$	17.17

*Mark of Schlumberger

Product Code: Prong-Type Equalizing Housing / 352

info@peakwellsystems.com | peakwellsystems.com

© 2017 Peak Well Systems Pty Ltd. All rights reserved. Revision: 20th August 2014

peak 
WELL SYSTEMS

Melon-Type Equalizing Prong

The Melon-Type Equalizing Prong is an integral component of the Melon-Type Equalizing Housing, a commonly used method of achieving pressure across a set plug. It incorporates a tell-tale to indicate when the Equalizing Melon has been displaced.

Recovery of the Melon-Type Equalizing Assembly requires two-runs-to-pull. The Melon-Type Equalizing Prong is run prior to the MATS/GS Pulling Prong to equalize pressure across the plug and allow safe recovery.

The Melon-Type Equalizing Prong is a simple design which is connected directly to a standard wireline toolstring incorporating Stem and Spang Jars. The Equalizing Prong is run into the plug and downward jarring severs the brass shear screws retaining the sealing Melon within the Equalizing Assembly. Once the Melon is moved "off-seat", equalization can take place.

APPLICATIONS

- To equalize the Melon Equalizing Housing

FEATURES AND BENEFITS

- Equalizing Prong incorporates tell-tale feature to ensure Melon has moved into the "off-seat" position
- Incorporates shearable centralizer to ensure the prong is guided into the plug correctly
- Supplied with industry standard Sucker Rod (SR) type connections
- Simplistic design with minimal components
- Robust design

TECHNICAL INFORMATION

To Suit Plug, in	Standard Length, in	Standard Connection*, in	Standard Fish Neck, in
2 3/8**			
2 7/8	49.6	15/16 SR	1.375
3 1/2	53.3	1 1/16 SR	1.750
4 1/2	53.5	1 1/16 SR	1.750
5	64.4	1 1/16 SR	1.750
5 1/2	67.3	1 1/16 SR	1.750

*Prong connection type and fish neck can be supplied to suit customer requirements.

**Does not include the Melon Equalizing Option.



Product Code: Melon-Type Equalising Prong / 352

info@peakwellsystems.com | peakwellsystems.com

© 2017 Peak Well Systems Pty Ltd. All rights reserved. Revision: 20th August 2014



Sealing/Equalizing Prong

The Sealing/Equalizing Prong is an integral component of the Prong-Type Equalizing Housing, a commonly used method of sealing and equalizing across the set plug downhole.

After the Prong-Type Equalizing Housing has been set, the sealing prong is run on a standard JD- or SB-type pulling tool to create the sealing plug. To allow safe recovery of the plug, the sealing prong is recovered with a standard JD- or SB-type pulling tool to ensure equalization has taken place prior to the MATS/GS pulling prong being deployed to recover the plug.

APPLICATIONS

- To provide an equalizing option for the Peak SIM* and SIMplus* Plug, in conjunction with the Prong Type Equalizing Housing

FEATURES AND BENEFITS

- Incorporates shearable centralizer and seal protector feature to ensure seals are protected whilst running in the well and that the prong is guided into the plug correctly
- Supplied with industry standard external type fish necks
- Can be supplied with internal fish neck/junk catcher to reduce number of runs if junk catcher is required above
- Shortened versions can be supplied to accommodate height restricted rig-ups threaded equalizing port options to control the rate of equalization
- Critical components ENP treated to prevent thread galling and corrosion
- Simplistic design with minimal components
- Robust design

TECHNICAL INFORMATION

To Suit Plug, in	Standard Length*, in	Standard Fish Neck*, in	Pulling Tool to Recover
2 ³ / ₈ **			
2 ⁷ / ₈	83.20	1.375	2 in Nominal JDC/SB
3 ¹ / ₂	84.90	1.750	2 1/2 in Nominal JDC/SB
4 ¹ / ₂	59.70	1.750	2 1/2 in Nominal JDC/SB
5	71.38	2.313	3 in Nominal JDC/SB
5 ¹ / ₂	73.38	2.313	3 in Nominal JDC/SB

*Prong length and fish neck can be supplied to suit customer requirements.

**Includes integral equalizing prong conveyed with plug.



Equalizing Prong

SIM Plug with Prong Equalizing Housing and Prong in place

*Mark of Schlumberger

Product Code: Sealing/Equalizing Prong / 352

info@peakwellsystems.com | peakwellsystems.com

© 2017 Peak Well Systems Pty Ltd. All rights reserved. Revision: 22nd August 2014



Pump Thru Check Valve

The Pump Thru Check Valve is designed to fit onto the Peak SIM* Plug and most standard wireline conveyed lock assemblies and is used where there is a requirement to hold tubing pressure from below whilst allowing a maximum pump through capability.

The Peak design incorporates several key differentiating features including a reversible metal-to-metal seal for optimum working life, a secondary bronze filled Teflon seal to initiate metal-to-metal sealing at low pressures and mass reduction in the piston valve to reduce stress loading on the Inconel Return Spring also designed to extend working life.

APPLICATIONS

- The Pump Thru Check Valve can be used when there is a requirement to hold tubing pressure from below whilst allowing a pump through capability

FEATURES AND BENEFITS

- Reversible metal-to-metal seal designed to extend working life
- Secondary bronze filled Teflon seal to initiate metal-to-metal sealing at low pressures
- Mass reduction in the Piston Valve reducing Return Spring stress extending working life
- Sour service components to industry specifications
- Robust and simplistic design

TECHNICAL INFORMATION

Nominal Lock Assembly, in	Pressure Rating*, psi
2 3/8	5,000
2 7/8	5,000
3 1/2	5,000
4 1/2	5,000
5	5,000
5 1/2	5,000
7	5,000

*Higher pressure ratings available on request.



*Mark of Schlumberger

Product Code: Pump Thru Check Valve / 335

info@peakwellsystems.com | peakwellsystems.com

© 2017 Peak Well Systems Pty Ltd. All rights reserved. Revision: 3rd April 2013

peak 
WELL SYSTEMS

Pump Open Sub

When deployed as part of a downhole plug assembly, the Pump Open Sub is primarily designed to act as a single barrier against wellbore contents.

The Pump Open Sub plunger is secured in place with a series of shear screws which are designed to shear out when a predetermined pressure is applied from above the Pump Open Sub.

Once the plunger is sheared out, there is a clear flow path through the Pump Open Sub. This allows for full equalization across the barrier device, circulation, communication to prevent recovery of "wet" tubing strings or production of wellbore contents.

APPLICATIONS

When deployed as part of a downhole plug assembly, the Pump Open Sub can be:

- Used as a barrier to allow setting of hydraulically-set packers having to make an equalizing run prior to plug recovery
- Remotely "opened" by pressuring the tubing above to the pre-set shear rating - the well can then be brought back online without any intervention
- Used for creating tubing overbalance prior to fracture stimulation operations
- Deployed as a contingent equalizing device in high debris environments
- Used as a mechanical barrier during wellhead removal/tree valve maintenance

FEATURES AND BENEFITS

- Can be retrofitted to suit existing lock mandrel/equalizing assemblies
- Multiple setting values (500-psi minimum - 5,000-psi maximum) in 500-psi increments
- Large flow area after pump out in flow type/circulating applications
- Sheared plunger retained within the sump of Pump Open Sub eliminating unnecessary well debris
- Minimizing wireline runs
- Can be sheared out even if debris restricts access to primary equalizing facility by applying sufficient pressure

TECHNICAL INFORMATION

To Suit SIM Lock, in	Tool OD, in	Pressure Rating*, psi
2 5/8	1.810	500 - 3,000
2 7/8	2.200	
3 1/2	2.720	500 - 5,000
4 1/2		
5		
5 1/2		
7		

*Higher shear pressure ratings available on request.

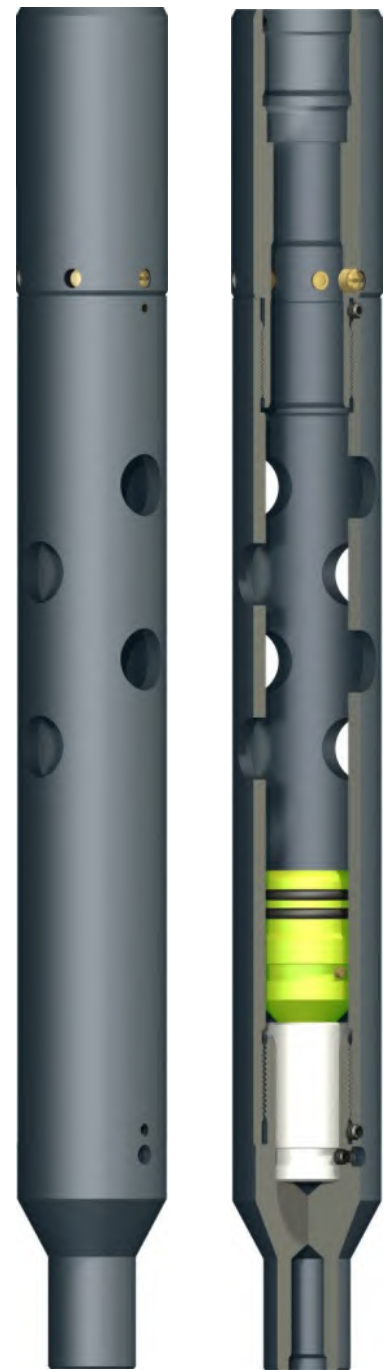

▲ Pump Open Sub

Product Code: Pump Open Sub / 300

info@peakwellsystems.com | peakwellsystems.com

© 2021 Peak Well Systems Pty Ltd. All rights reserved. Revision: 13 October 2021



Plug Pulling Tool

The Plug Pulling Tool is designed for trouble-free recovery of Peak's retrievable SIM* and SIMplus* System products.

The Plug Pulling Tool incorporates a unique feature whereby, when initially run in the hole, downward jar action can be applied without the danger of prematurely shearing the pulling tool's contingent release mechanism.

APPLICATIONS

- Recovery of Peak's retrievable SIM and SIMplus Plugs

FEATURES AND BENEFITS

- Contingent release shear pin is initially protected whilst latching the plug
- The pin protection feature allows for a smaller shear rating pin to be run in the release mechanism. This can be of huge benefit in high deviation wells
- Easily redressable in remote locations

TECHNICAL INFORMATION

Nominal Plug, in	Multi-Action Top Sub	Nominal GS, in	Pulling Prong
2 $\frac{3}{8}$	A207-1810-XXX	2	353-1810-001-01
2 $\frac{7}{8}$	A207-2250-XXX	2 $\frac{1}{2}$	353-2200-001-01
3 $\frac{1}{2}$	A207-2720-XXX	3	353-2720-001-01
4 $\frac{1}{2}$	A207-3620-XXX	4	353-3600-001-01
5	A207-3620-XXX	4	353-4050-001-01
5 $\frac{1}{2}$	A207-4500-XXX	5	353-4450-001-01



*Mark of Schlumberger

Product Code: Plug Pulling Tool / 207/229/353

info@peakwellsystems.com | peakwellsystems.com

© 2017 Peak Well Systems Pty Ltd. All rights reserved. Revision: 20th August 2014

peak 
WELL SYSTEMS



Flow Control (Nipple Products)

Simple Safe Assured

Peak Standing Valve

The Peak Standing Valve addresses an industry need for a suitably sized standing valve for use within a DST string to allow maximum throughbore.

Differing from a standing valve that locks into a nipple profile, the Peak Standing Valve is a sit-on, No-Go design that tests the integrity of tubing connections and downhole jewellery situated above the standing valve.

With no lock-out feature, the wire and toolstring can remain attached to the standing valve during pressure test operations, minimizing both deployment and recovery times.

The Peak Standing Valve can be designed to fit any standard Top No-Go or Bottom No-Go profile nipple with a seal bore.

FEATURES AND BENEFITS

- Integral equalizing feature to prevent pulling against any hydrostatic head
- Standard rope socket fishing neck allowing running and recovery on standard pulling tools.
- No special running tool required
- Spring-on-ball design is suitable for high deviation applications
- Reduces NPT by remaining latched onto standing valve during testing



Product Code: Standing Valve / 304

info@peakwellsystems.com | peakwellsystems.com

© 2017 Peak Well Systems Pty Ltd. All rights reserved. Revision: 28th August 2014

peak 
WELL SYSTEMS

FloSafe Lock Mandrel

The FloSafe Lock Mandrel is a flow-secure locking device with a positive, confirmatory tell-tale mechanism in the FloSafe Running Tool, designed for the safe and correct deployment of Wireline Retrievable Safety Valves (WRSV).

The FloSafe Lock Mandrel is retrofittable to suit the uppermost X-type nipple profile. It prevents the possibility of unknowingly setting the WRSV incorrectly thanks to a positive, confirmatory shear pin tell-tale feature incorporated into the FloSafe Running Tool. If the FloSafe Running Tool returns in the sheared position, the Expander Mandrel/Fish Neck has not fully travelled, confirming that the FloSafe Lock Mandrel has not fully set.

To prevent FloSafe from opening and unseating the WRSV, a unique internal collet engagement feature prevents the expander mandrel from opening during flowing conditions.

APPLICATIONS

- Safe and correct deployment of Wireline Retrievable Safety Valves

FEATURES AND BENEFITS

- 100% retrofittable to suit existing uppermost Otis X-type nipple profiles
- FloSafe incorporates a flow-secure collet engagement feature, preventing flowing fluid or gas turbulence from opening the FloSafe Neck
- FloSafe Running Tool incorporates simple shear pin tell-tale feature to indicate FloSafe has correctly set
- FloSafe and the FloSafe Running Tool are of a simple design with no special tools required for redress
- Supplied with lower connection options to suit customer requirements
- Industry standard GS/GR type pulling tools required for retrieval of FloSafe
- Material options available to suit customer requirements
- Currently available for 2 7/8-in, and 3 1/2-in tubing - various sizes are available on request to suit customer requirements



Product Code: FloSafe Lock Mandrel / 380

info@peakwellsystems.com | peakwellsystems.com

© 2017 Peak Well Systems Pty Ltd. All rights reserved. Revision: 31st December 2013

peak 
WELL SYSTEMS



Well Monitoring

Simple Safe Assured

Large Bore Gauge Hanger

Peak's Large Bore Gauge Hanger can be used to carry data acquisition devices or can be set as an anchor for instruments or equipment that require suspension in the wellbore.

The Large Bore Gauge Hanger can be set 100% mechanically using slickline but extends to allow setting on all other available industry standard deployment methods. It has an extremely high load capacity and is ideal for use in high flow rate wells.

APPLICATIONS

- Gauge hanger for pin-point real time and memory data acquisition
- Anchoring device to provide a platform for, or suspension of, Stack-Up Perforating Guns, Swellable Packers, Sampling Gauges, etc.
- To act as a barrier to prevent unwanted movement of abandoned equipment in flowing wells

FEATURES AND BENEFITS

- Extreme high load capacity - ideal for high flow rate wells or high weight stack-up applications
- Large through-bore for increased flow rate
- Can be set 100% mechanically anywhere in the tubing with the fully patented Peak SIM Running Tool (UK Patent No: GB2432607 & GB2424237)
- Recoverable with the GS Pulling Tool
- Compact design making utilization ideal in height restricted rig-ups
- Simple, robust design
- Lower connection options available to suit customer requirements

TECHNICAL INFORMATION

Nominal Tubing Size, in	Tubing Weight, lbm/ft	Actual Gauge Hanger OD, in	Flow Area*, in ²	GS to recover, in
2 7/8	6.4 - 7.8	2.200	2.00	2 1/2
3 1/2	9.2 - 10.2	2.700	3.54	3
4 1/2	10.5 - 15.1	3.600	6.95	4
5	15 - 20.3	4.050	7.61	4
5 1/2	17 - 23	4.450	9.60	5
7	23 - 32	5.650	15.10	6

*Flow areas will vary slightly between different tubing weights for the same OD tubing.



▲ The Large Bore Gauge Hanger can be set 100% mechanically on slickline using the SIM Running Tool.

Product Code: Large Bore Gauge Hanger / 340

info@peakwellsystems.com | peakwellsystems.com

© 2017 Peak Well Systems Pty Ltd. All rights reserved. Revision: 3rd April 2013

peak 
WELL SYSTEMS

Hi-Ex Gauge Hanger

The Peak Hi-Ex Gauge Hanger can be used to deploy data acquisition devices on slickline and can be used as an anchor to provide a platform for, or suspend, other equipment in non-monobore wells.

The Hi-Ex Gauge Hanger is a slim, high expansion design which allows it to be deployed on slickline through narrow restrictions or smaller completion tubing, and set in larger ID liners/casings. Most importantly, the slim design minimizes the restriction to flow enabling better quality data to be recorded during production and/or injection conditions.

The Hi-Ex Gauge Hanger comes in chassis size 2.200-in OD. Adapter kits enable the gauge hanger to be set in a range of tubing sizes from 4 1/2 in to 9 5/8 in.

APPLICATIONS

- Gauge hanger for pin-point real time and memory data acquisition during well testing, production monitoring and other applications – particularly in non-monobore wells
- Anchoring device to provide a platform for, or suspension of, swell-able packers, fluid samplers, etc. in non-monobore wells
- Platform for cement plugs in well abandonments
- Barrier to prevent unwanted movement of abandoned equipment in flowing wells

FEATURES AND BENEFITS

- Slickline deployed
- High-expansion mechanism allows one Hi-Ex Gauge Hanger assembly to be used in various tubing/casing sizes
- Slim design for maximum flow/injection rates and minimal impact on data quality
- Run using the Peak eSetting Tool (non-explosive)
- Recoverable with industry standard pulling tools
- Simple, robust design
- Standard lower connection 15/16 in-10 UN SR. Other options available to suit customer requirements

TECHNICAL INFORMATION

Nominal Tubing Size [†] , in	Tubing Weight, lbm/ft	Actual Gauge Hanger OD, in	Flow Area ^{††} , in ²	HD FRC to Recover, in
3 1/2	7.7 – 9.2	2.200	3.1 – 2.4	2.220
4 1/2	9.5 – 15.1	2.200	7.9 – 5.8	2.220
5	≥ 18.0	2.200	≤ 9.0	2.220
5 1/2	15.5 – 38.0	2.200	13.2 – 6.3	2.220
6 5/8	≥ 24.1	2.200	≤ 19.2	2.220
7	≥ 35.0	2.200	≤ 19.7	2.220
7 5/8	39.0 – 59.2	2.200	27.2 – 19.1	2.220

[†] Solutions for nominal tubing sizes > 7 5/8-in (e.g. 9 5/8-in) are available on request.

^{††} Flow areas will vary slightly between different tubing weights for the same OD tubing.



Product Code: Hi-Ex Gauge Hanger / 341

info@peakwellsystems.com | peakwellsystems.com

© 2019 Peak Well Systems Pty Ltd. All rights reserved. Revision: 10th May 2019

peak 
WELL SYSTEMS

eSetting Tool

Peak's nonexplosive eSetting Tool is used to deploy Peak's Hi-Ex Gauge Hanger to any location in the wellbore using simple slickline operations.

The eSetting Tool provides a reliable deployment technique without the need for pyrotechnics, pressurized nitrogen or complex hydraulic pumps.

Simple actuation using the pre-programmed electronic timer system gives full operational flexibility and control across a broad range of different operating environments and well depths.

The force required to set the Hi-Ex Gauge Hanger is derived from a staged spring mechanism in the eSetting Tool and is capable of securely setting Hi-Ex Gauge Hangers in all sizes of casing. The low-power electronic timer is powered by small Lithium batteries making for easy transportation and rapid deployment of the complete system in the field.

At depth, the eSetting Tool activates and sets the Hi-Ex Gauge Hanger, expanding its arms to the tubing wall and securely anchoring and centralizing itself inside the tubing via the bidirectional slips. Once the Hi-Ex Gauge Hanger is set, the eSetting Tool automatically releases from the hanger. The ability to disarm the timer by upward jarring provides a fail-safe system in the event of operational difficulties.

APPLICATIONS

- Used for the deployment of 2.200-in Hi-Ex Gauge Hangers on slickline
- Rated to 10,000 psi, 177 degC

FEATURES AND BENEFITS

- Simplified logistics: safe and rapid mobilization to well sites globally
- Integrated non-hydraulic, non-pyrotechnic power system
- No radio-silence requirement, reducing NPT
- Disposable, low cost electronics, for simple field redress
- Range of pre-programmed countdown times for operational flexibility and control
- Emergency jar-up feature to disarm the timer

TECHNICAL INFORMATION

Nominal Tubing Size, in	Weight, † lbm/ft	Gauge Hanger OD, in
4 ½	11.6 - 13.5	2.2
5	15 - 24.1	2.2
5 ½	17 - 26	2.2
7	≤ 32	2.2

† Adaptor subs are available for all tubing weights within the above sizes. Contact Peak Well Systems' representatives for setting Hi-Ex Gauge Hanger in tubing weights outside of the ranges stated above.



eSetting Tool

peak 
WELL SYSTEMS

Product Code: eSetting Tool / 342

info@peakwellsystems.com | peakwellsystems.com

© 2019 Peak Well Systems Pty Ltd. All rights reserved. Revision: 10th December 2019



Well Integrity

Simple Safe Assured

Leak Detection Tool

The Leak Detection Tool is designed to create a temporary sealing barrier to enable a surface pressure test to ascertain a potential leak path between the tubing and annulus.

Using the proven SIM* Running Tool, the Leak Detection Tool is deployed in the well to a desired depth, predominantly at a depth below a suspected leak path, on a conventional slickline toolstring. Reciprocation at depth allows the radial indexing mechanism to activate, anchoring the Running Tool slips to the tubing wall. To effect the "seal", light jarring down is required to expand the element of the Leak Detection Tool. Tubing pressure is then applied to test tubing integrity. The cycle can then be repeated and fine tuned until the exact location of a leak is detected.

APPLICATIONS

- As a temporary barrier to identify the location of a downhole leak
- To determine the position of tubing to annulus communication
- To check the integrity of older wells

FEATURES AND BENEFITS

- Leak Detection device which can be reset a number of times without the need to pull back to surface
- Multiple setting capability reduces NPT by allowing the leak to be pinpointed quickly, minimizing wireline runs
- Holds pressures of 1,500 psi at 350 degF from above
- The integral self-equalizing device allows the pressure to equalize across the elastomer cup before moving the elastomer into the fully retracted position
- Simple, robust design
- The mechanical Leak Detection Tool can be supplied as an Adapter System to the patented SIM Running Tool (UK Patent No: GB2432607 & GB2424237)
- The Leak Detection Tool can also be purchased as a complete system packaged in conjunction with the patented SIM Running Tool (UK Patent No: GB2432607 & GB2424237)
- Currently available for 2 3/8-in, 2 7/8-in, 3 1/2-in, and 4 1/2-in tubing, however various sizes are available on request to suit customer requirements

TECHNICAL INFORMATION

Nominal Tubing Size, in	Tubing Weight, lbm/ft	Actual OD, in	Pressure Rating, psi	Temperature Rating, degF
2 3/8	4.6	1.810	1,500	350
2 7/8	6.4 - 7.8	2.220	1,500	350
3 1/2	9.2 - 10.2	2.720	1,500	350
4 1/2	10.5 - 17.1	3.650	1,500	350



*Mark of Schlumberger

Product Code: Leak Detection Tool / 362

info@peakwellsystems.com | peakwellsystems.com

© 2019 Peak Well Systems Pty Ltd. All rights reserved. Revision: 11th October 2019



peak 
WELL SYSTEMS

Tubing Alignment Tool

The Peak Tubing Alignment Tool is designed to realign and create a conduit across parted tubing, allowing remedial work to be conducted below the tubing break.

The tool does not create a pressure seal as it is designed primarily to allow a deep set barrier to be placed below the tubing break in order to make the well safe prior to further remedial intervention.

The design of the Tubing Alignment Tool is highly subject to each individual application, dependent on location and nature of the tubing break.

APPLICATIONS

- Restoring well integrity in older 'brown' fields
- Allowing the setting of deep set barrier below break in completion tubing to make well safe
- Making wells safe prior to rig conducting workover

FEATURES AND BENEFITS

- Simple slickline deployment and installation
- Can be recovered to surface if required
- Flexible design that allows for easy in-field set up once the length of the tubing gap is ascertained
- Can be supplied with various options for landing-off in the upper section of tubing
- Maximum through bore to allow passage of deep set plug on slickline or e-line
- Will pass through most standard TRSCSSSV nipples
- Recovered using standard GS-type Pulling Tool
- Locking and No-Go fingers can be included for added retention
- Tailor made solutions for all tubing sizes

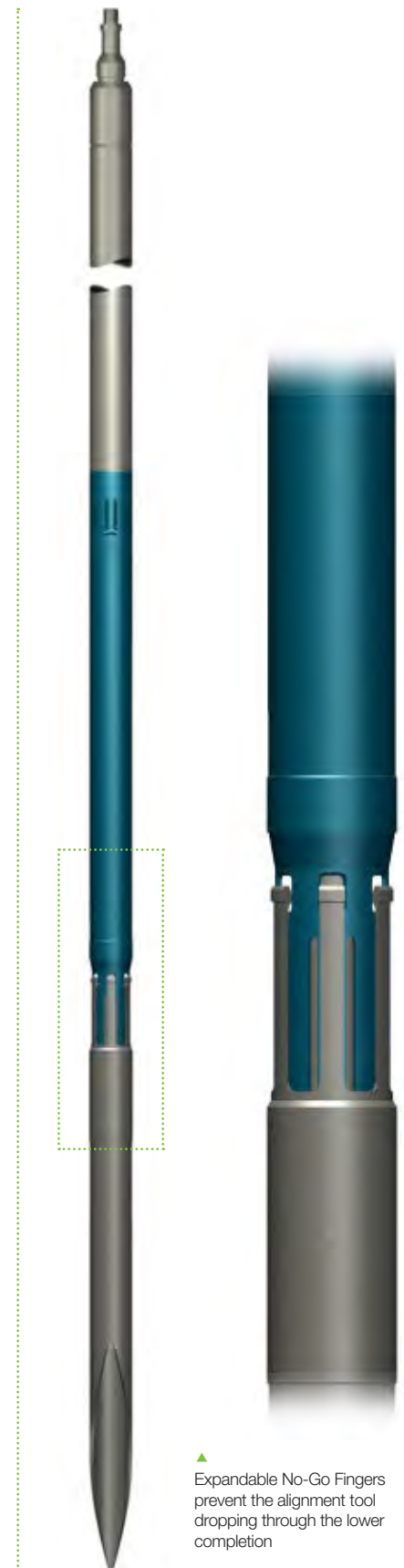

▲ Expandable No-Go Fingers prevent the alignment tool dropping through the lower completion

Product Code: Tubing Alignment Tool / 290

info@peakwellsystems.com | peakwellsystems.com

© 2017 Peak Well Systems Pty Ltd. All rights reserved. Revision: 25th September 2013

peak 
WELL SYSTEMS



Production Enhancement

Simple Safe Assured

Top Latch Choke

The Top Latch Choke is designed to be receivable within a Peak SIM* or SIM^{PLUS}* Plug, creating a Downhole Choke thus allowing the plug to be used to choke back well fluids as desired.

Peak's Plug Systems have a unique arrangement where the downhole choke can be recovered to surface without recovering the plug body. This means the choke can be recovered and resized to meet flow requirements without the added runs required to pull and reset a plug - reducing further runs/time and also removing plug redress costs.

APPLICATIONS

- Control oil or gas flow between two or more sands to control cross flow and improve overall reservoir performance
- To control gas flow from a gas reservoir below an existing oil reservoir and provide natural gas lift
- To control fluid flow from differing reservoirs to give a controlled fluid mix from the well, for example to balance gas dilutions between high and low CO₂ content gas

FEATURES AND BENEFITS

- Choke can be recovered and reset without the need to pull the plug
- Integral equalizing ensures no chance of being blown up hole should the orifice become blocked
- Run and recovered on industry standard pulling tools
- Easily changed tungsten carbide orifice disc

TECHNICAL INFORMATION

Nominal Tubing Size, in	Tool OD, in	Dual Fish Neck Size, in
2 7/8	2.200	1.375 / 1.437
3 1/2	2.720	1.750 / 1.812



*Mark of Schlumberger

Product Code: Top Latch Choke / 358

info@peakwellsystems.com | peakwellsystems.com

© 2017 Peak Well Systems Pty Ltd. All rights reserved. Revisio: 20th August 2014



FloWell

FloWell* is a dynamic underbalance system designed to improve productivity by the removal of skin and perforation damage.

FloWell is a slickline deployable system that can be used to create a dynamic underbalance across a pre-determined interval within a monobore/pseudo-monobore completion string.

The system utilizes Peak's unique field proven SIM* and SIM^{PLUS*} Plug Systems as a means of zonal isolation between which the FloWell System is run and activated.

Its modular design offers flexibility and enables varying lengths of sand face to be treated. The packer isolation alleviates any chance of unwanted stimulation in zones of no interest.

APPLICATIONS

- To remove formation damage in perforation tunnels
- Recover injectivity in injection wells

FEATURES AND BENEFITS

- Uses standard slickline tools and running procedures
- Safe – 100% mechanical, no pyrotechnics or electronics required
- Modular design allowing any length of zone to be treated
- Easily field redressable in remote locations
- Sized to pass through standard completion restrictions
- Standard fishing neck design for simple recovery
- High temperature applications up to 350 degF
- Cost-effective means of improving productivity



*Mark of Schlumberger

Product Code: FloWell / 420

info@peakwellsystems.com | peakwellsystems.com

© 2017 Peak Well Systems Pty Ltd. All rights reserved. Revision: 17th December 2015

peak 
WELL SYSTEMS



Fishing Systems

Simple Safe Assured

Full Radial Contact Gas Lift Valve Pulling Tool

Peak's Full Radial Contact (FRC) Gas Lift Valve (GLV) Pulling Tool is used in conjunction with a kickover tool for recovering gas lift valves during GLV change-out operations.

The FRC GLV Pulling Tool is designed to engage the full 360 degree underside of an external fish neck and is generally used in conventional and heavy jarring applications. The full contact area provides a much greater load bearing area compared to standard two or three dog-type pulling tools which are commonly used in GLV changeout operations. The full supporting latch finger face reduces the amount of damage to both the latch fingers and the fish neck to be recovered by evenly distributing the load whilst also improving impact transmission, greatly increasing chances for successful recovery.

Incorporating a positive locking key feature and expansion profiles on the core and latch fingers, ensures clean disengagement from the GLV during downward jarring. The FRC GLV Pulling Tool does not rely upon springs and steel memory for disengagement which also makes re-pinning safe and easy.

APPLICATIONS

- Retrieval of gas lift valves in conventional or heavy jarring applications

FEATURES AND BENEFITS

- Cores available to suit top and bottom latch GLV's
- Suits all standard SPM pockets and GLV latches
- Full 360 degree (FRC) latch finger coverage
- 'Jar down to release' - positive locking core and latch finger expansion profile feature to assist in safe tool disengagement
- Simple and safe to redress - no special pinning tools required
- Additional cores available to suit special reach requirements
- Robust design

TECHNICAL INFORMATION

Nominal Size, in	Actual OD, in	To Engage, in	Fish Neck, in
1 1/2	1.350	0.875 (1-in GLV)	1.187
1 3/4	1.750	1.187 (1 1/2-in GLV)	1.187
1 3/4	1.750	1.187 (1 1/2-in GLV)	1.375



Product Code: Full Radial Contact Gas Lift Valve Pulling Tool / 206

info@peakwellsystems.com | peakwellsystems.com

© 2017 Peak Well Systems Pty Ltd. All rights reserved.

peak
WELL SYSTEMS

Heavy-Duty Full Radial Contact Pulling Tool (Jar Up to Shear)

The Heavy-Duty Full Radial Contact (HD FRC) Pulling Tool (Jar Up to Shear) will engage the Peak signature HD 45 degree Fish Neck and a standard 90 degree Fish Neck. The HD FRC is designed for use in applications where it is not desirable or feasible to run a 'jar down to shear' Pulling Tool. This may include recovery of wire and/or fishing in highly deviated conditions.

APPLICATIONS

- Where a 'jar down to shear' tool is not the preferred option due to the nature of the fish or well conditions
- Conveyance and recovery of Peak Wire Retrieval System where a 'jar up to release' function is required

FEATURES AND BENEFITS

- Angled latch fingers make releasing in high angle wells trouble free
- Incorporates Peak signature 45 degree heavy-duty latch finger face which creates easier release from 90 degree type fishing necks in high-angle wells
- 360 degree full radial contact latch fingers mean heavy pulling weights are spread evenly across latch and fishing neck
- Optional Bell Guide Bottom Subs for use in larger ID tubulars
- 'Jar up to release' feature
- Two shear pin size options
- Robust design

TECHNICAL INFORMATION

Nominal Size, in	Actual Tool OD, in	To Engage Fish Neck, in
2	2.220	1.375 and 1.437
2 1/2	2.600	1.750 and 1.812
3	3.250	2.313 and 2.375

Note: Bell Guide Bottom Sub option available to suit customer requirements.



Product Code: Heavy-Duty Full Radial Contact Pulling Tool (Jar Up to Shear) / 224

info@peakwellsystems.com | peakwellsystems.com

© 2017 Peak Well Systems Pty Ltd. All rights reserved.

peak 
WELL SYSTEMS

Heavy-Duty Full Radial Contact Pulling Tool (Jar Down to Shear)

The Peak Heavy-Duty Full Radial Contact (HD FRC) Pulling Tool (Jar Down to Shear) will engage the Peak signature HD 45 degree Fish Neck and a standard 90 degree Fish Neck. The HD FRC is designed for use in applications where heavy upward jarring is required to retrieve a stuck fish with a 'jar down to release' function.

The Peak signature HD 45 degree Fish Neck has a 60% increased load bearing area to that of standard fish necks. The 360 degree 'full radial contact' design of the HD FRC Latch Fingers increases impact transmission through the fish during continuous heavy upward jarring. The HD FRC has a 'jar down to release' and locking core feature allowing it to be safely retrieved back to surface if required.

APPLICATIONS

- Heavy upward jarring applications with a 'jar down to release' function

FEATURES AND BENEFITS

- Built to withstand prolonged heavy upward jarring
- Incorporates Peak signature 45 degree HD Latch Finger face with a 60% increased load bearing area compared to standard latch fingers
- 360 degree full radial contact Latch Fingers minimize flaring of fish neck and increase impact transmission
- Optional Bell Guide Bottom Subs for use in larger ID tubulars
- 'Jar down to release' feature
- Two shear pin size options
- Robust design

TECHNICAL INFORMATION

Nominal Tubing Size, in	Actual Tool OD, in	To Engage Fish Neck, in
2 7/8	2.220	1.375 and 1.437
3 1/2	2.600	1.750 and 1.812
4 1/2	3.250	2.313 and 2.375
5 1/2	4.150	3.125

Note: Bell Guide Bottom Sub option available to suit customer requirements.



Product Code: Heavy-Duty Full Radial Contact Pulling Tool (Jar Down to Shear) / 228

info@peakwellsystems.com | peakwellsystems.com

© 2017 Peak Well Systems Pty Ltd. All rights reserved.

peak 
WELL SYSTEMS

Heavy-Duty Pulling System

The Heavy-Duty Pulling System is designed for use in applications where heavy upward jarring is required to retrieve a stuck fish.

The system is comprised of two tools - a Heavy-Duty Full Radial Contact (HD FRC) Pulling Tool and a Non-Releasable Replacement Rope Socket (NRRS).

The principle of the system is that the Non-Releasable Replacement Rope Socket can be run on a conventional 'jar up to shear' Pulling Tool and set onto the fish neck of the stuck fish and in conjunction with the HD FRC Pulling Tool.

The HD FRC Pulling Tool will engage the Peak HD Dual Fish Neck of the Non-Releasable Replacement Rope Socket. Heavy upwards jarring can then commence to retrieve the stuck fish. The HD FRC Pulling Tool has a 'jar down to release' and locking core feature allowing it to be safely retrieved back to surface if required.

APPLICATIONS

- Replacement of damaged fish necks
- Heavy upward jarring applications

FEATURES AND BENEFITS

- Built to withstand prolonged heavy upward jarring
- Incorporates Peak signature 45 degree heavy-duty latch finger face with a 60% increased load bearing area compared to standard latch fingers
- 360 degree full radial contact latch fingers minimize flaring of fish neck and increase impact transmission
- Optional Bell Guide Bottom Subs for use in larger ID tubulars
- HD FRC Jar Up Adapter option available
- 'Jar down to release' feature
- Two shear pin size options
- Robust design

TECHNICAL INFORMATION - HD FRC

Nominal Size, in	Actual Tool OD, in	To Engage, in
2	2.220	1.437
2 1/2	2.600	1.812
3	3.250	2.375

TECHNICAL INFORMATION - NRRS

Nominal Size, in	Actual Tool OD, in	Upper Fish Neck, in	Lower HD Fish Neck, in
2	2.220	1.375	1.437
2 1/2	2.600	1.750	1.812
3	3.250	2.313	2.375



NRRS shown latched onto the Peak HD Dual Fish Neck

Product Code: Heavy-Duty Pulling System / 211/228

info@peakwellsystems.com | peakwellsystems.com

© 2017 Peak Well Systems Pty Ltd. All rights reserved. Revision: 3rd April 2013



Double Jar Down Adaptor

The Double Jar Down Adaptor can be fitted to a Full Radial Contact (FRC) and Heavy-Duty FRC (HD-FRC) Pulling Tool to recover an external fishing neck.

Unlike the FRC Pulling Tool which has a fixed 'jar down to release' mode, the Double Jar Down Adaptor enables repetitive jarring down as needed to latch the fish without the inherent risk of prematurely shearing the 'jar down to release' pin.

If the fish cannot be recovered, the upper pin in the Double Jar Down Adaptor will shear thus allowing subsequent downward jarring to release the Pulling Tool.

APPLICATIONS

- Gas lift work
- High deviation well intervention

FEATURES AND BENEFITS

- Can be used to retrofit Peak's FRC Pulling Tool
- Reduces toolbox inventory
- Simple shear pin to redress
- Reduced NPT due to elimination of premature shearing of pin

TECHNICAL INFORMATION

Nominal Tubing Size, in	Tool OD, in	Fits FRC Sizes, in	Overall Length, in
2 3/8	1.750	1.750	13.19
2 7/8	2.220	2.220	17.32
3 1/2	2.600	2.600	19.25
4 1/2	3.250	3.250	18.86



Product Code: Double Jar Down Adaptor / 233

info@peakwellsystems.com | peakwellsystems.com

© 2017 Peak Well Systems Pty Ltd. All rights reserved.



DJD FRC Pulling Tool

The double jar down full radial contact (DJD FRC) pulling tool is used for external fishing neck recovery.

The DJD FRC pulling tool enables repetitive downward jarring to latch the fish without an inherent risk of prematurely shearing the jar-down-to-release pin.

The tool shears the upper pin in the DJD adaptor if the fish cannot be recovered—allowing subsequent downward jarring to release the pulling tool.

APPLICATIONS

- High-cost well intervention
- Gas lift work

FEATURES AND BENEFITS

- Reduces toolbox inventory by eliminating separate JD, JU, and double JU FRC tools
- Enables robust jarring down and up without damage to the tool
- Simplifies redressing with quick exchange of shear pin, screws, pins, and springs
- Increases range of use with two shear pin size options
- Reduces NPT by eliminating premature shearing of the pin
- Increases versatility with specialized cores for gas lift work and all types of cable heads
- Saves time and effort with simple and smooth release of fingers from fish neck once sheared
- Handles larger-ID tubing with optional Bell Guide Bottom Subs
- Offers heavy duty pulling tool option: HD DJD FRC

TECHNICAL INFORMATION

Nominal Tubing Size, in	Length, in [mm]	Tool OD, in [mm]	To Engage Fish Neck, in [mm]
2 3/8	21.50 [546.1]	1.690 [42.9]	1.187 [30.2]
2 7/8	28.50 [723.9]	2.220 [56.4]	1.375 and 1.437 [34.9 and 36.5]
3 1/2	30.75 [781.1]	2.600 [66]	1.750 and 1.812 [44.4 and 46]
4 1/2	30.00 [762]	3.250 [82.6]	2.313 and 2.375 [58.8 and 60.3]
5 1/2	30.25 [768.4]	4.150 [105.4]	3.125 [79.4]

Note: Bell guide bottom sub option available to suit customer requirements.



Product Code: DJD FRC Pulling Tool / 234

info@peakwellsystems.com | peakwellsystems.com

© 2021 Peak Well Systems Pty Ltd. All rights reserved. Revision: 17 August 2021

peak 
WELL SYSTEMS

Internal Neck

Full Radial Contact Pulling Tool

The **Internal Neck Full Radial Contact (IN FRC) Pulling Tool** is designed to meet a market demand for a heavy-duty tool suitable for the recovery of downhole equipment fitted with internal Otis-type fish necks.

APPLICATIONS

- Recovery of stuck down hole devices fitted with internal Otis-type fish necks
- Engaging badly scaled fish necks
- Retrieval of items with worn or damaged fish necks

FEATURES AND BENEFITS

- Contact area between latch fingers and fish neck 30% greater than standard GS Pulling Tool Dogs
- No powerful springs for safe assembly and disassembly
- Stepped latch fingers to minimize required downward travel to shear off
- One piece collet style latch fingers
- Latch finger grip increases as line pull increases
- Locking Core to assist in safe tool release
- Optional serrated latch fingers available
- Robust design
- Simple to redress
- J-Slot release feature to easily disengage tool from fish neck at surface
- Two shear pin size options
- Available in all standard GS sizes

TECHNICAL INFORMATION

Nominal GS Size, in	Actual OD, in	Fish Neck to Engage, in
2	1.810	1.38
2 1/2	2.220	1.81
3	2.720	2.31
3 1/2	3.110	2.62
4	3.620	3.12
5	4.500	4.00
6	5.600	4.75
7	5.875	5.38



Product Code: Internal Neck Full Radial Contact Pulling Tool / 210

info@peakwellsystems.com | peakwellsystems.com

© 2017 Peak Well Systems Pty Ltd. All rights reserved.

peak 
WELL SYSTEMS

Heavy-Duty Releasable Overshot

The heavy-duty releasable overshot is designed for the recovery of downhole items with missing or damaged external fish necks.

The 'jar down to release' feature provides the option of running the tool directly connected to the toolstring. Once sheared the core is locked in the release position to ensure the Overshot will disengage from the fish.

APPLICATIONS

- Engaging items with damaged or missing external fish necks
- Alternative to the heavy-duty non-releasable overshot

FEATURES AND BENEFITS

- Adjustable core for varying reach
- Interchangeable slips to engage varying OD's
- Slips interchangeable between releasable and non-releasable versions
- Optional bell guide bottom subs for use in larger ID tubulars
- 'Jar down to release' feature
- Locking core feature to assist in safe tool release
- Simple to redress/re-pin for quick turnaround between wireline runs
- Two shear pin size options
- Inventory reduction

TECHNICAL INFORMATION

Nominal Tubing Size, in	Actual OD, [†] in	Slip Range, [‡] in	Reach, in
2 7/8	2.22	0.625 - 1.375	1.83 - 3.99
3 1/2	2.72	0.4 - 1.625	2.12 - 4.19
4 1/2	3.35	1 - 2.375	2.52 - 4.91
	3.7	1 - 2.375	2.52 - 4.91
5 1/2	4.5	1,000 - 3.500	2.68 - 4.89
7	5.5	1,000 - 3.500	2.84 - 5.05

[†] These housing OD's and slip sizes are suitable for heavy-duty 5/16-in braided line fishing. Smaller OD housings are available for light- to medium-duty fishing operations.

[‡] Bell guide bottom housing option available to suit customer requirements.



▲ Heavy-duty releasable overshot



Product Code: Heavy-Duty Releasable Overshot / 230

info@peakwellsystems.com | peakwellsystems.com

© 2020 Peak Well Systems Pty Ltd. All rights reserved. Revision: 21st October 2020.



Heavy-Duty Non-Releasable Overshot

The heavy-duty non-releasable overshot is used for the retrieval of downhole items with damaged or missing external fish necks.

The overshot is 'planted' onto the fish to provide a new fish neck profile. This is then engaged with a standard releasable pulling tool or a Peak heavy-duty full radial contact pulling tool for heavy jarring applications.

APPLICATIONS

- Replacing damaged or missing external fish necks
- Providing a new fish neck profile for releasable pulling tools to engage

FEATURES AND BENEFITS

- Adjustable core for varying reach
- Interchangeable slips to engage varying ODs
- Slips interchangeable between releasable and non-releasable versions
- Multiple running neck options - multi-pin running tool, heavy-duty dual fish neck etc.
- Optional bell guide bottom subs for use in larger ID tubulars
- Bypass ports through tool body to provide maximum flow area if fish cannot be recovered
- Robust design
- Inventory reduction

TECHNICAL INFORMATION

Nominal Tubing Size, in	Actual OD, [†] in	Slip Range, [‡] in	Reach, in
2 3/8	1.75	0.5 - 1	1.6 - 3.1
2 7/8	2.22	0.625 - 1.375	1.8 - 4.0
3 1/2	2.72	0.4 - 1.625	2.1 - 4.2
4 1/2	3.7	1.125 - 2.375	2.5 - 5
5 1/2	4.85	1 - 3.5	2.7 - 5

[†] These housing OD's and slip sizes are suitable for heavy-duty 5/16-in braided line fishing. Smaller OD housings are available for light- to medium-duty fishing operations.

[‡] Bell guide bottom housing option available to suit customer requirements.



▲ Heavy-duty non-releasable overshot



Product Code: Heavy-Duty Non-Releasable Overshot / 231

info@peakwellsystems.com | peakwellsystems.com

© 2020 Peak Well Systems Pty Ltd. All rights reserved. Revision: 21st October 2020.

peak 
WELL SYSTEMS

Heavy-Duty Releasable Spear

The heavy-duty releasable spear is used for the recovery of downhole items with missing or damaged internal fish necks.

An adjustment sleeve varies the reach of the tool and interchangeable slips are fitted to suit the inside diameter that the spear needs to engage.

With the spear's reach correctly adjusted and if required, a release pin can be sheared by downward jarring. Once sheared, a positive locking feature will ensure that the slips remain retracted, allowing the toolstring and spear to disengage from the fish for safe recovery back to the surface.

The 'jar down to release' feature provides the option of running the tool directly connected to the toolstring.

APPLICATIONS

- Retrieval of items with damaged or missing internal fish necks

FEATURES AND BENEFITS

- Reach adjustment sleeve to suit varying engagement depth of slips
- Interchangeable slips for engaging varying internal diameters
- Slips interchangeable between releasable and non-releasable versions
- 'Jar down to release' feature
- Positive locking feature to assist in safe tool release
- Simple to re-dress/re-pin for quick turnaround between wireline runs
- Robust design
- Inventory reduction

TECHNICAL INFORMATION

Nominal Tubing Size, in	Actual OD, in	Slip Range, in	Reach, in
2 ⁵ / ₈	1.75	1 - 1 ¹ / ₂	3.25
2 ⁷ / ₈	2.2	1 ¹ / ₄ - 2	3.7
3 ¹ / ₂	2.7	1 ⁵ / ₈ - 2 ¹ / ₂	3.4
4 ¹ / ₂	3.62	2 ³ / ₈ - 3 ¹ / ₂	6
5 ¹ / ₂	4.5	3 ¹ / ₂ - 4 ⁷ / ₁₆	5.75
7	5.5	4 ¹ / ₁₆ - 5 ³ / ₈	4.56

Note: Customized slips and spear sizes available.



▲ Heavy-duty releasable spear

Product Code: Heavy-Duty Releasable Spear / 204

info@peakwellsystems.com | peakwellsystems.com

© 2020 Peak Well Systems Pty Ltd. All rights reserved. Revision: 21st October 2020.

peak 
WELL SYSTEMS

Heavy-Duty Non-Releasable Spear

The heavy-duty non-releasable spear is used for the recovery of downhole items with missing or damaged internal fish necks.

An adjustment sleeve varies the reach of the tool and interchangeable slips are fitted to suit the inside diameter that the spear is required to engage. The spear can be set using a conventional jar up to shear tool and retrieved using a Peak heavy-duty full radial contact (HD FRC) pulling tool.

APPLICATIONS

- Retrieval of items with damaged or missing internal fish necks

FEATURES AND BENEFITS

- Reach adjustment sleeve to suit varying engagement depth of slips
- Interchangeable slips for engaging varying inside diameters
- Slips interchangeable between releasable and non-releasable versions
- Integral Peak heavy-duty dual fish neck
- Simple to redress
- Robust design
- Inventory reduction

TECHNICAL INFORMATION

Nominal Tubing Size, in	Actual OD, in	Slip Range, in	Reach, in
2 ³ / ₈	1.75	1 - 1 ¹ / ₂	3.26
2 ⁷ / ₈	2.2	1 ¹ / ₄ - 2	3.71
3 ¹ / ₂	2.7	1 ⁵ / ₈ - 2 ¹ / ₂	3.25
4 ¹ / ₂	3.62	2 ³ / ₈ - 3 ¹ / ₂	6.02
5 ¹ / ₂	4.5	3 ¹ / ₂ - 4 ⁷ / ₁₆	5.75

Note: Customized slips and spear sizes available.



▲
Heavy-duty non-releasable spear

Product Code: Heavy-Duty Non-Releasable Spear / 212

info@peakwellsystems.com | peakwellsystems.com

© 2020 Peak Well Systems Pty Ltd. All rights reserved. Revision: 21st October 2020.

peak 
WELL SYSTEMS

Wireline Retrieval System

The Peak Wireline Retrieval System consists of a combination of interchangeable tool components used for the process of locating and recovering parted wireline.

The system incorporates a unique design feature which allows the Slotted Finder Finger Sleeve to be adjusted to any chosen diameter to suit a range of nominal tubing ID and nipple dimensions.

APPLICATIONS

- Safely locating the top of parted wire
- Balling over the top of wire
- Latching and retrieving wire back to surface

FEATURES AND BENEFITS

- Fully interchangeable components
- Adjustable Finder Finger Sleeve
- Extension Bar options
- Option to run in conjunction with Peak Centre Spear, a two-, three- or four-Prong Wireline Grab, Lead Impression Block, or Adjustable Finder Finger Sleeve
- Multiple Running Neck options
- Robust design
- Inventory reduction

TECHNICAL INFORMATION

Nominal Tubing Size, in	Actual OD, in	Finger Adjustment Range, in
2 3/8	1.750	1.750 - 1.992
2 7/8	2.195	2.195 - 2.441
3 1/2	2.701	2.701 - 2.992
4	3.100	3.100 - 3.548
4 1/2	3.600	3.600 - 3.992
5 1/2	4.530	4.530 - 4.892
7	5.512	5.512 - 6.138
9 5/8	8.125	8.125 - 8.681



Product Code: Wireline Retrieval System / 200

info@peakwellsystems.com | peakwellsystems.com

© 2019 Peak Well Systems Pty Ltd. All rights reserved. Revision: 15th May 2019

peak 
WELL SYSTEMS

Wireline Centre Spear

The Wireline Centre Spear can be run independently or in conjunction with the Peak Wire Retrieval System for the purpose of recovering parted wire back to surface.

The optional Peak Wire Retrieval System utilizes a unique design feature which allows the Slotted Finder Sleeve to be adjusted to any chosen diameter to suit a range of nominal tubing ID and nipple dimensions.

APPLICATIONS

- For retrieval of parted wireline from within the wellbore

FEATURES AND BENEFITS

- Option to run in conjunction with the Peak Adjustable Finder Finger Sleeve to prevent the Centre Spear passing the top of the parted wire
- Multiple barbs for latching and retrieving balled wire
- Adaptor Sub supplied with industry standard connections
- Rounded barb profile to prevent cutting of fished wire on high pulls
- Robust design
- Inventory reduction

TECHNICAL INFORMATION

Nominal Tubing Size, in	Fish Neck, in
2 3/8	1.375
2 7/8	1.375
3 1/2	1.750
4	1.750
4 1/2	1.750
5 1/2	1.750
7	1.750

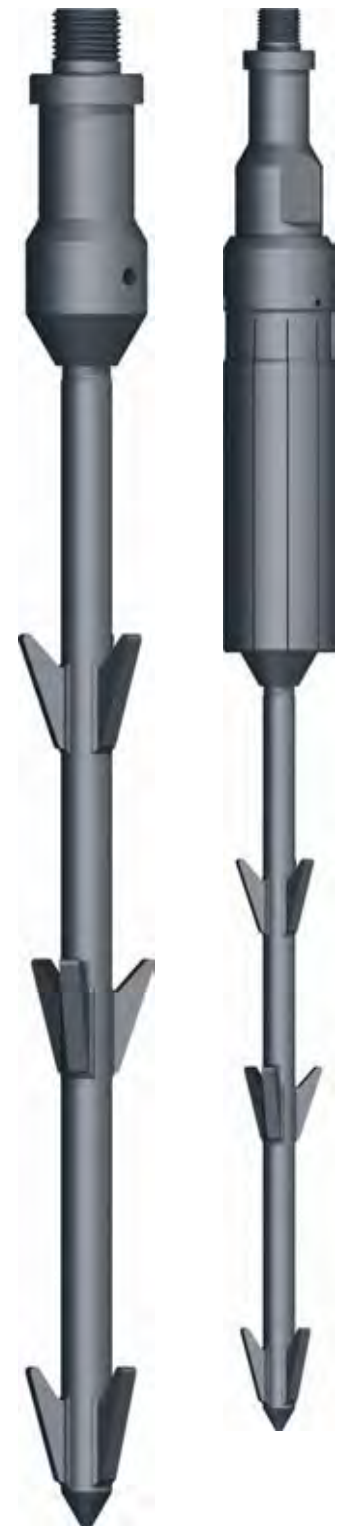

▲ Centre Spear with Slotted Finder Sleeve

Product Code: Wireline Centre Spear / 202

info@peakwellsystems.com | peakwellsystems.com

© 2017 Peak Well Systems Pty Ltd. All rights reserved.

peak 
WELL SYSTEMS

Tapered Wire Retriever

The Tapered Wire Retriever is used for the process of locating and recovering parted wireline in a single run.

Peak's Tapered Wire Retriever incorporates a unique design feature which allows the Slotted Finder Finger Sleeve to be adjusted to any chosen diameter to suit a range of nominal tubing ID and nipple dimensions.

APPLICATIONS

- Safely locating the top of parted wire
- Latching and retrieving wire back to surface

FEATURES AND BENEFITS

- Peak Adjustable Finder Finger Sleeve
- Extension Bar options
- Multiple Running Neck options
- Robust design
- Inventory reduction

TECHNICAL INFORMATION

Nominal Tubing Size, in	Actual OD, in	Finger Adjustment Range, in
2 3/8	1.750	1.750 - 1.992
2 7/8	2.195	2.195 - 2.441
3 1/2	2.701	2.701 - 2.992
4	3.100	3.100 - 3.548
4 1/2	3.600	3.600 - 3.992
5 1/2	4.530	4.530 - 4.892
7	5.512	5.512 - 6.138

Note: Larger sizes available on request.



Product Code: Tapered Wire Retriever / 213

info@peakwellsystems.com | peakwellsystems.com

© 2017 Peak Well Systems Pty Ltd. All rights reserved.

peak 
WELL SYSTEMS

Multi-Pin Running Tool

Multi-Pin Running Tools (MPRT) are designed for use primarily as shearable devices which can be connected to a variety of tools such as Wireline Grabs, Wire Finders, Perforating Gun Drifts, Retrievable Bridge Plug Drifts, Non-Releasable Overshots and Spears etc.

With 'jar-up' and 'jar-down to shear' options, the MPRT can also be used to deploy Junk Catchers or Sealing Prongs. Internal and external fish neck options provide the operator with the flexibility to choose the device which best suits the well geometry and operation to be performed.

APPLICATIONS

- Utilized as safety shear-out device for fishing applications including conveyance of Wireline Grabs, Wire Finders, Non-Releasable Overshots and Spears etc.
- Conveyance of extended, rigid assemblies including Perforating Gun Drifts, Retrievable Bridge Plug Drifts etc.
- Deployment of Junk Catchers and Sealing Prongs

FEATURES AND BENEFITS

- Internal and external fish neck options to suit well geometry and operation
- All Internal Neck Subs suit all standard GS and Peak IN FRC sizes
- External Neck Sub incorporates a standard fish neck and Peak HD Chamfered Fish Neck which is aligned for use with the Peak HD FRC Pulling Tool for ultra-heavy jarring applications
- 'Jar-up' and 'jar-down to release' functions
- Multiple pinning options to suit varied applications
- Simple to re-pin
- Robust design

TECHNICAL INFORMATION - External Multi-Pin Running Tool and Fish Neck Sub

Actual OD, in	Contingent Recovery Fish Neck, in
2.125	1.375 / 1.437
2.600	1.750 / 1.812
3.250	2.313 / 2.375

TECHNICAL INFORMATION - Internal Multi-Pin Running Tool and Fish Neck Sub

Actual OD, in	Contingent Recovery Fish Neck, in
1.810	1.380
2.200	1.810
2.720	2.313
3.116	2.620
3.620	3.120
4.500	4.000
5.830	5.380



Product Code: Multi-Pin Running Tool / 201

info@peakwellsystems.com | peakwellsystems.com

© 2017 Peak Well Systems Pty Ltd. All rights reserved.



Heavy-Duty Dual Fish Neck Sub

The Heavy-Duty (HD) Dual Fish Neck Sub is used to provide a secondary heavy-duty fish neck profile in addition to the conventional fish neck profile.

The 45 degree secondary Peak HD Fish Neck has a 60% increased load bearing area compared to standard fish necks. This is designed for use in conjunction with the Peak HD FRC Pulling Tool and can withstand prolonged heavy jarring impact.

APPLICATIONS

- For use as a running and retrieval neck on Wire Grabs, Non-Releasable Overshots, Non-Releasable Spears, etc

FEATURES AND BENEFITS

- Peak HD Fish Neck has a 60% increased load bearing area compared to standard fish necks and is designed for use in conjunction with the Peak HD FRC Pulling Tool
- 45 degree profile of the Peak HD Fish Neck assists in tool release after prolonged upward jarring
- 45 degree profile of the Peak HD Fish Neck assists in tool release at high angles in deviated wellbores
- Conventional upper neck profile for use with industry standard running and pulling tools
- Bottom connection supplied to suit customer requirements
- Robust design

TECHNICAL INFORMATION

Actual OD, in	Primary Neck, in	Secondary Neck, in
1.500	1.375	1.437
1.875	1.750	1.812
2.500	2.313	2.375



▲ HD FRC Pulling Tool engaging the Peak HD Dual Fish Neck

Product Code: Heavy-Duty Dual Fish Neck Sub / 123

info@peakwellsystems.com | peakwellsystems.com

© 2017 Peak Well Systems Pty Ltd. All rights reserved.

peak 
WELL SYSTEMS

Multi-Action Top (MAT) Sub

Provides pinning and repinning options in combination with GS pulling and running tools for applications and wireline intervention operations.

The MAT sub provides multiple pinning options to vary the shear-to-release mode of the GS pulling or running tool that it's fitted to. Repinning is simplified with a safer, built-in rearming tool.

APPLICATIONS

- Recovery of downhole flow devices
- Fishing applications that require a jar up to release option
- Setting of downhole items that requires a jar down to release option

FEATURES AND BENEFITS

- Simplifies redressing with quick exchange of shear pin, screws, pins, and springs
- Streamlines repinning with safer, built-in rearming tool
- Facilitates retrofitting
- Minimizes misruns with three running-mode options:
 - Jar down to shear
 - Jar up to shear
 - Jar up, followed by jar down to shear
- Performs reliably with robust materials and downhole design to industry-standard ODs
- Reduces toolbox inventory by eliminating separate tools for jarring up, jarring down, and double jarring down

TECHNICAL INFORMATION

Nominal Tubing Size, in [mm]	Tool OD, in [mm]	To Engage Fish Neck †, in [mm]
2	1.810 [46]	1.38 [35.1]
2 ½	2.250 [57.2]	1.81 [46]
3	2.720 [69.1]	2.31 [58.7]
3 ½	3.110 [79]	2.62 [66.6]
4	3.620 [92]	3.12 [79.2]
5	4.500 [114.3]	4.00 [101.6]
6	5.560 [141.2]	5.00 [127]
7	5.875 [149.2]	5.25 [133.4]

† When made up to appropriate GS pulling tool.



Standard GS Pulling Tool fitted with the Peak Multi-Action Top Sub

Product Code: Multi-Action Top (MAT) Sub / 207

info@peakwellsystems.com | peakwellsystems.com

© 2021 Peak Well Systems Pty Ltd. All rights reserved. Revision: 17 August 2021

peak 
WELL SYSTEMS

Integral Bell Guide Bottom Housing

The Integral Bell Guide Bottom Housing is fitted to tools to increase the effective diameter of the tool inside larger tubing and casing diameters.

APPLICATIONS

- For use in conjunction with Peak and third-party tools inside larger ID tubing and casing

FEATURES AND BENEFITS

- Increase the effective catchment area of the tool skirt
- Fits directly to the tool body
- Supplied in any diameter to suit customer requirements
- Fluted option for fluid bypass
- Roller option for use in high-angle/deviated wells
- Robust design
- Inventory reduction



▲ Releasable Overshot shown with Integral Bell Guide Bottom Housing

Product Code: Integral Bell Guide Bottom Housing / 118

info@peakwellsystems.com | peakwellsystems.com

© 2017 Peak Well Systems Pty Ltd. All rights reserved.

peak 
WELL SYSTEMS

Impression Block Orientation Indicator

The Impression Block Orientation Indicator is an important component during operations where understanding the position of a fish within the tubing is critical.

The Orientation Indicator can be fitted to an Impression Block and activation of the sub is simultaneous with the downward jar whilst obtaining an impression. This downward jar action forces a mandrel to impress against a non-magnetic steel ball and a leaded bronze disc.

The ball which is free within the chamber will always rest against the low side so the impression obtained on the brass disc can be referenced directly with the impression on the block. Confirming the low side of the tubing in relation to the position of the fish greatly assists the operator in selecting the correct tool for the next stage in the recovery operation.

APPLICATIONS

- Determining low side of wellbore in relation to fish to enhance recovery operations

FEATURES AND BENEFITS

- Simplistic design
- Reusable Bronze Impression Disc for cost effectiveness and inventory reduction
- Lead free for ease of use, quick turnaround and handling
- Simple ratchet release mechanism for positive engagement and quick redress
- Can be made up to any Impression Block equal to, or greater than, 2.500-in OD
- Connection options available to suit customer requirements



▲ Impression Block Orientation Indicator made up to the Peak Impression Block (PIB)

Product Code: Impression Block Orientation Indicator / 226

info@peakwellsystems.com | peakwellsystems.com

© 2017 Peak Well Systems Pty Ltd. All rights reserved. Revision: 11th September 2013

peak 
WELL SYSTEMS

Indexing Tool

Improves fish recovery by rotating the toolstring BHA on a radial J-slot mechanism.

With simple sit-down and pick-up action, the Indexing Tool rotates and increases coverage of the lower connected tool within the wellbore. This increases the probability of recovering a fish that may be resting in a position that makes standard recovery difficult.

APPLICATIONS

- Stuck tool recovery operations

FEATURES AND BENEFITS

- Increases flexibility for use across different tubing sizes and downhole toolstring options
- Provides minimum three-point indexing system, even with smaller-OD tools
- Ensures continuous rotation at a consistent angle via spring-assisted J mandrel, regardless of deviation
- Offers greater flexibility with multiple upper- and lower-connection options
- Enhances fish recovery in deviated and larger-bore completions, with optional customized eccentric lower threading
- Improves application for special customer requirements, using customized designs

TECHNICAL INFORMATION

Tool OD, in [mm]	Fish Neck, in [mm]	Length, in [mm]
1.875	1.750 [44.4]	16.9 [429.3]
2.250	1.750 [44.4]	17.2 [436.9]
2.500	2.313 [58.8]	18.0 [457.2]



Product Code: Indexing Tool / 222

info@peakwellsystems.com | peakwellsystems.com

© 2021 Peak Well Systems Pty Ltd. All rights reserved. Revision: 17 August 2021

peak 
WELL SYSTEMS

Tubing End Locator

The Tubing End Locator is a device used to locate the end of a specific size of completion string or broken tubing in order to confirm its accurate position in the wellbore for further depth-critical intervention work.

The device can be run as part of a toolstring or, more commonly, directly on the bottom of the toolstring.

APPLICATIONS

- Locate tubing end/break in tubing
- Depth correlation

FEATURES AND BENEFITS

- Sprung loaded arm enhances ability in high deviation situations
- Simple shear pin release allows for over pull to be taken and safely recovered to surface
- Sizes to suit 2 3/8 in to 7 in
- Available with all common toolstring connections

TECHNICAL INFORMATION

Tool OD, in	To Suit Tubing, in	Fish Neck Size, in
1 1/2	2 7/8	1.375
1 7/8	2 7/8	1.750
	3 1/2	1.750
	4 1/2	1.750
	5 1/2	1.750
2 1/2	3 1/2	1.750
	4 1/2	1.750
	5 1/2	1.750
	7	1.750



Product Code: Tubing End Locator / 135

info@peakwellsystems.com | peakwellsystems.com

© 2017 Peak Well Systems Pty Ltd. All rights reserved.



Pump Down Go-Devil

The Peak Pump Down Go-Devil is designed to assist in remedial wire recovery operations where a cutter with a time delay activation device is dropped from surface.

The Pump Down Go-Devil can be used to 'chase' the cutter to the desired hold-up depth in deviated/horizontal wells.

It is offered with either two flexible elastomer cups or two rigid Teflon cups where toughness is a requirement that will pass through downhole restrictions and allow recovery to surface after the wire cut is achieved.

APPLICATIONS

- Pump time delay cutter bar to depth in high-angle wells

FEATURES AND BENEFITS

- Available in two lengths
- Longer option designed to pass through GLM's whilst retaining seal
- Designed to pass through restrictions
- Tool can be fitted to wire on surface without need to cut
- Available to suit various wire/cable diameters
- Swab cups available in elastomer or Teflon material



▲ Pump Down Go-Devil with elastomer swab cups

▲ Pump Down Go-Devil with Teflon swab cups

Product Code: Pump Down Go-Devil / 122

info@peakwellsystems.com | peakwellsystems.com

© 2018 Peak Well Systems Pty Ltd. All rights reserved. Revision: 10th December 2018

peak 
WELL SYSTEMS

Sidewall Cutter

The Sidewall Cutter is used to cut slickline wire against the tubing wall. This may be required to clear the well past the Tubing Retrievable Subsurface Safety Valve (TRSSSV) or to clear down to ball of wire.

The device is activated by simple manipulation of the running string or by sitting down on an obstruction. Downward jarring drives the hardened blades radially outwards until contact with the wire. Subsequent jarring severs the wire at this point.

APPLICATIONS

- Fishing
- Well integrity

FEATURES AND BENEFITS

- Emergency release feature that can be pinned with steel or brass shear stock
- Hardened blades field proven to cut the hardest slickline wire up to 0.14 in
- Available in sizes to suit common tubing widths
- Full radial coverage of cutting blades within tubing ID
- Supplied with shearable Running Tool
- Cutting blade activation can be pinned with bi-directional to shear 1/8-in shear pin

TECHNICAL INFORMATION

Nominal Tubing Size, in	Actual OD, in	Max. Expansion of Cutting Blades, in
2 7/8	2.00	2.52
3 1/2	2.30	3.00
4 1/2	3.40	3.92
5 1/2	4.15	4.90
7	5.22	6.32



Product Code: Sidewall Cutter / 214

info@peakwellsystems.com | peakwellsystems.com

© 2019 Peak Well Systems Pty Ltd. All rights reserved. Revision: 14th January 2019

peak 
WELL SYSTEMS

Peak Cutter

The Peak Cutter is a unique, power-charged, non-explosive cutter that is dropped from surface to sever slicklines and cables in the event that a toolstring becomes stuck downhole.

It is designed to cut cleanly above the toolstring assembly - safely and reliably - and allow the upper section of the wire/cable to be recovered quickly to surface.

APPLICATIONS

- Deployment in the event that a toolstring becomes stuck downhole
- Recovery of wire or cable from situations where wire or tools have been blown up hole
- Deployment in subsea wells where the Peak Cutter is held as a contingency within a tool catcher integral to the seabed well control package

FEATURES AND BENEFITS

- Incorporates an integral non-hydraulic, non-pyrotechnic power charge, a contingent cutting arrangement and integral wire/cable clamp assembly
- No need for explosives, so the Peak Cutter is also safe to deploy
- Capable of cutting all industry wire from 0.108-in slickline up to 5/16-in heavy-duty Dyform cable
- Supplied with three retaining plates which cover full 0.108-in – 0.312-in range of tool
- Rollerized versions are available on request subject to completion size
- Simple field redress
- Supplied with safety clamp for secure and safe handling at the well site
- Offers an accurate and reliable result, particularly when deployed in high viscous fluids and deviated wells
- Available for rapid rental with immediate mobilization
- Does not require radio silence

TECHNICAL INFORMATION

Actual OD, in	Fish Neck Size, in	Length, in
2.185	1.375	45.0
2.500*	2.313	44.4
2.800 (Rollerized)	1.375	43.7

*Rollerized versions available on request.

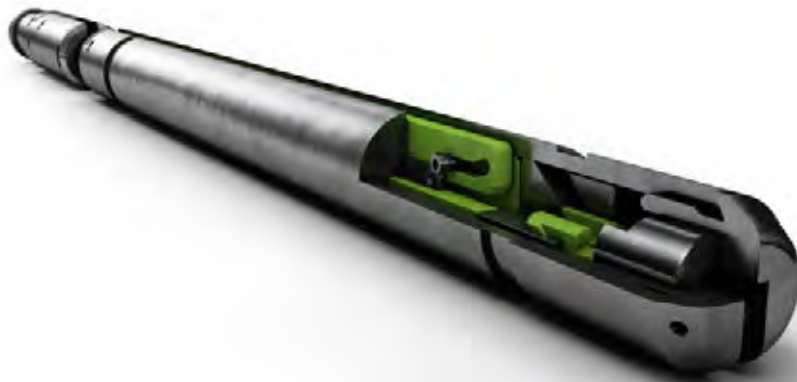

Product Code: Peak Cutter / 215

info@peakwellsystems.com | peakwellsystems.com

© 2017 Peak Well Systems Pty Ltd. All rights reserved. Revision: 26th September 2017

peak 
WELL SYSTEMS

Peak eCutter

The Peak eCutter is a unique, electronically activated, power-charged, non-explosive cutter that is dropped from surface to sever slicklines and cables in the event that a toolstring becomes stuck downhole.

The Peak eCutter is a variant of the standard Peak Cutter whereby, rather than being activated by impact against the stuck toolstring, the Peak eCutter is activated via an electronic timer and trigger module. Providing the same elements of unparalleled safety and reliability to cleanly cut a wide range of wire sizes as the field-proven standard Peak Cutter, the Peak eCutter provides the ultimate operational flexibility and functionality to ensure that the cut is performed at the required point especially in highly deviated or complex geometry wells.

APPLICATIONS

- Deployment in all stuck toolstring events for target depth and activation assurance
- Severing of wire and cable in highly deviated wells
- Pump-Down deployment

FEATURES AND BENEFITS

- Integral non-pyrotechnic power charge
- No radio silence requirement
- HSE compliant: No explosives
- Range of pre-programmed countdown times (optional custom-programming also available)
- Remote power capability with lithium-based power source
- LED operability indicator for timer activation confirmation
- Same tool capable of cutting all industry wire/cables from 0.108-in slickline to 5/16-in heavy-duty Dyform cable
- Supplied with safety handling clamps for safe and secure operations at the well site
- Offers a reliable and accurate result even in highly deviated wells, high viscous fluids and complex geometries
- Roller Centralizers available for larger tubing/casing sizes
- Pump-Down systems available upon request
- Simple field redress
- Logistically simple, safe and rapid mobilization to well sites globally

TECHNICAL INFORMATION

Actual OD, in	Fish Neck Size, in	Length, in
2.200	1.375	88.01
2.500*	1.375	87.94
2.800 (Rollerized)	1.375	88.01

*Range of roller centralizers and pump-down available for all tubing sizes 4½ in and above.



Product Code: Peak eCutter / 215

info@peakwellsystems.com | peakwellsystems.com

© 2017 Peak Well Systems Pty Ltd. All rights reserved. Revision: 26th September 2017

peak 
WELL SYSTEMS

High-Pressure Peak eCutter

The High-Pressure Peak eCutter* electronically activated nonexplosive wireline cutter drops from surface to sever slicklines and cables when a toolstring becomes stuck downhole.

The High-Pressure Peak eCutter cutter is specifically designed to withstand high pressures up to 20,000 psi.

It is activated via an electronic timer and trigger module. Preprogrammed countdown times and optional custom programming capabilities support target depth and activation assurance. The cutting action is driven by a patented mechanical actuator with the timer and trigger module powered by a small onboard lithium battery.

It performs clean cuts above the toolstring assembly in a wide range of wire sizes from 0.108-in slickline to 0.440-in heavy-duty cable enabling the upper section of wire or heavy-duty cable to be retrieved to surface.

Robust blades and a cable gripping system offer a safer, more reliable, and accurate result.

APPLICATIONS

- High pressure well environments
- Wells at any deviation
- Complex geometry wells
- Pumpdown deployment
- High-viscosity fluids

FEATURES AND BENEFITS

- The integral nonpyrotechnic power charge eliminates the requirement for radio-frequency silence during operations.
- LED operability indicator provides timer activation confirmation
- Supplied with safety handling clamps for safe and secure operations at the well site

TECHNICAL INFORMATION

Tool OD, in [mm]	Fish Neck Size, in [mm]	Length, in [mm]	Wire Size, in [mm]	Pressure rating, psi [MPa]	Temperature Rating [†] , degF [degC]
2.700	1.750 [44.45]	112.6 [2,860.04]	0.108 to 0.440 [2.743 to 11.176]	20,000 [137.89]	165 [329]

[†] Applies to specific battery and electronics assemblies.



*Mark of SLB

Product Code: High-Pressure Peak eCutter / 216

info@peakwellsystems.com | peakwellsystems.com

© 2023 Peak Well Systems Pty Ltd. All rights reserved. Revision: 4 January 2023



▲ High-Pressure Peak eCutter



Heavy-Duty eCutter

The Heavy-Duty eCutter is a unique, electronically activated, power-charged nonexplosive cutter used to sever heavy-duty wireline cables when a toolstring becomes stuck downhole.

Like the field-proven Peak eCutter, the Heavy-Duty eCutter incorporates an electronic timer and trigger module that introduces a time-based delay allowing a pre-designated time to elapse before the cutting function is activated. The electronics module is designed to operate safely and reliably in temperatures up to 177 degC [350 degF].

Upon activation, the Heavy-Duty eCutter cuts cleanly above the toolstring assembly to allow the upper section of the wire/cable to be recovered quickly to surface. Its simple design incorporates robust blades and gripping systems that enable it to cleanly cut 0.3125-in to 0.5900-in heavy-duty wire/cable safely, reliably, and accurately - even in highly deviated wells, high viscous fluids, and complex geometry wells.

APPLICATIONS

- Deployment in all stuck toolstring events for target depth and activation assurance
- Severing of heavy-duty wire/cable in highly deviated and complex geometry wells
- Pump-Down deployment

FEATURES AND BENEFITS

- Integral non-pyrotechnic power charge
- No radio-silence requirement
- HSE compliant: No explosives
- Range of pre-programmed countdown times (optional custom-programming also available)
- Remote power capability with lithium-based power source
- LED operability indicator for timer activation confirmation
- Standard (150 degC [302 degF]) and high temperature (177 degC [350 degF]) electronics (specific battery and electronics assemblies)
- Same tool capable of cutting all industry wire/cables from 0.3125-in to 0.5900-in heavy-duty wire/cable
- Supplied with safety handling clamps for safe and secure operations at the well site
- Robust blades and cable gripping system offer a reliable and accurate result even in highly deviated wells, high viscous fluids and complex geometry wells
- Pump-Down systems available upon request
- Simple field redress
- Logistically simple, safe and rapid mobilization to well sites globally

TECHNICAL INFORMATION

Actual OD, in	Fish Neck Size, in	Length, in	Wire Size, in	Max. Temperature, degC [degF]
3.250	2.313	93.58	0.3125 – 0.5900	177 [350]



Product Code: Peak Heavy-Duty eCutter / 215

info@peakwellsystems.com | peakwellsystems.com

© 2019 Peak Well Systems Pty Ltd. All rights reserved. Revision: 2nd September 2019

peak 
WELL SYSTEMS

Peak Impression Block (PIB)

The Peak Impression Block (PIB) is a unique lead-free tool for taking high definition impressions of objects, known or unknown, within the wellbore. The PIB reduces operating time, whilst offering a safer and more environmentally friendly alternative to lead impression blocks (LIBs).

The PIB uses high-performance, rapid-change inserts that eliminate the health and environmental issues associated with lead used in LIBs. PIB Inserts can be changed quickly and easily within seconds, enabling used inserts to be kept as a permanent record of operation. The PIB is also ideally suited to higher temperature applications where traditional lead-based impression blocks would be unsuitable.

A single jar down is all that is required to obtain a high definition impression. Upon recovery, the used PIB Insert is simply removed from the main body and replaced with a new insert. The PIB is instantly ready for redeployment, enabling the used insert to be kept for analysis.



APPLICATIONS

- To provide an impression of foreign or incorrectly positioned obstructions within the wellbore

FEATURES AND BENEFITS

- Lead-free: Eliminates health and environmental issues issued with standard LIBs (no filling of lead offshore, no melting lead, no hazardous fumes or hot metal)
- High definition imprints
- Simple to use and rapid to replace inserts within seconds.
- Single-use inserts offer a permanent record of operation
- Working temperature of 620 degF: High resistance to heat in excess of 450 degF that would melt standard lead inserts
- Available in four standard OD sizes for 2 7/8-in, 3 1/2-in, 4 1/2-in, 5 1/2-in, and 7-in completions

TECHNICAL INFORMATION

Nominal Tubing Size, in	Standard PIB OD, in			
	1.500	1.750	2.000	2.150
2 7/8	1.500	1.750	2.000	2.150
3 1/2	2.250	2.500	2.750	N/A
4 1/2	3.000	3.250	3.500	3.600
5 1/2	3.900	4.250	4.500	4.600
7	5.000	5.250	5.600	5.900
Standard Connection*	15/16-in SR	1 1/16-in SR	1 1/16-in SR	1 9/16-in SR

*Other connections available upon request.



Note: Patent Pending

Product Code: Peak Impression Block / 111

info@peakwellsystems.com | peakwellsystems.com

© 2017 Peak Well Systems Pty Ltd. All rights reserved. Revision: 29th January 2014





Premium Utility Toolstring

Simple Safe Assured

Compact Toolstring

The Compact Toolstring (CTS) is designed for use where available rig up height is limited, and for improved conveyance in highly deviated wells.

Depending on the well geometry, the customer has the option to incorporate or remove components which will ensure optimum operational performance.

The CTS can be split into two main categories, the 'Power' version and the 'Setting' version. Both versions can be extended to include an Integral Dual Neck Rope Socket, Swivel, and WellGlide complete with interchangeable rollers.

APPLICATIONS

- For use in rig ups with limited height availability
- For use in high-angle/deviated wells

FEATURES AND BENEFITS

- The base 'Power' version includes the Peak Power Jar (Inverted Upstroke Spring Jar), Accelerator and Linear Jar, available with 1 3/4-in, 1 7/8-in, 2 1/8-in or 2 1/2-in Peak Power Jars
- The base 'Setting' version includes the Peak Dummy Power Jar, Linear Jar and Heavy Stem section, and is used predominantly for installing devices where Hydraulic or Spring Jars are not required
- Configuration options extended to include an Integral Dual Neck Rope Socket, Swivel and WellGlide
- Reduced overall length
- Robust design

TECHNICAL INFORMATION - Power Version

Tool OD, in	Optional Roller Range, in	Length Open/ Closed, ft	Power Jar, in	Jar Range, lbs
2.720	N/A	12.2 / 9.3	1.75	300-1,250
2.800	2.950 - 3.500	12.2 / 9.3	1.75	300-1,250
3.350	3.500 - 4.700	12.0 / 9.0	1.875 (default) 2.125 [†] (optional)	300-1,250 400-3,000
3.500	N/A [‡]	15.0 / 11.5	2.500	600-4,000

TECHNICAL INFORMATION - Setting Version

Tool OD, in	Optional Roller Range, in	Length Open/ Closed, ft
2.720	N/A	9.6 / 7.5
2.800	2.950 - 3.500	9.6 / 7.5
3.350	3.500 - 4.700 ^{††}	7.1 / 9.2

[†] 2.125-in jar option requires a conversion kit

[‡] Uses Peak's WellGlide selection

^{††} Larger sizes available on request



Setting version (L), Power version (R)

Product Code: Compact Toolstring / 110

info@peakwellsystems.com | peakwellsystems.com

© 2021 Peak Well Systems Pty Ltd. All rights reserved. Revision: 9th April 2021



Slickline Rope Socket

Designed to attach the wireline to the toolstring, the Slickline Rope Socket incorporates a robust Sleeve feature which is designed to maintain form and ensure continuous performance.

Should the Rope Socket and toolstring be left in the well due to unforeseen circumstances and the wire has been recovered, the Heavy-Duty Full Radial Contact (HD FRC) Pulling Tool can be run to engage the Peak Heavy-Duty Dual Fish Neck; and prolonged, heavy jarring can be carried out, if required, to recover the toolstring.

APPLICATIONS

- To provide connection of the wireline to the toolstring

FEATURES AND BENEFITS

- Robust Pear Drop and Sleeve feature: Maintains form and ensures continuous performance
- Peak signature HD Dual Fish Neck: Allows use of both standard pulling tools and Peak HD FRC Pulling Tool range for recovery
- Suits all wire sizes
- Third-party proprietary connections available to suit customer requirements

TECHNICAL INFORMATION

Actual OD, in	Fish Neck, in
1.250	1.187
1.500	1.375 / 1.437
1.750	1.375 / 1.437
1.875	1.750 / 1.812
2.125	1.750 / 1.812
2.500	2.313 / 2.375



Product Code: Slickline Rope Socket / 123

info@peakwellsystems.com | peakwellsystems.com

© 2017 Peak Well Systems Pty Ltd. All rights reserved.



Slick & Swivel Rope Socket

The Slick & Swivel Rope Socket is designed to reduce the overall length of a toolstring by removing the requirement for an extra connection.

The working life of alloy slicklines can be extended when a swivel is incorporated below the rope socket. The swivel assists the tool rotation and prevents 'over-torque' of the wire. The integral configuration ensures that a swivel is always included in the toolstring.

APPLICATIONS

- For use with slickline operations

FEATURES AND BENEFITS

- Integral Rope Socket & Swivel: Reduces overall toolstring length and ensures a swivel is incorporated into the slickline toolstring
- Heavy-Duty Thrust Bearings: Enhance rotation under load
- Integral Grease Nipple: Allows easy lubrication and prevents corrosion
- Critical components ENP treated to further assist in prevention of internal corrosion
- Heavy-duty robust design
- Integral Belleville Spring design: Guarantees a positive load is maintained on the thrust bearings and thus ensures continuous rotation
- Debris Rings: Prevent ingress of foreign matter
- Swivel components are supported at rotation point to prevent lateral movement and wear
- Third-party proprietary connections available to suit customer requirements

TECHNICAL INFORMATION

Actual OD, in	Fish Neck, in
1.500	1.375 / 1.437
1.750	1.375 / 1.437
1.875	1.750 / 1.812
2.125	1.750 / 1.812
2.500	2.313 / 2.375



Product Code: Slick & Swivel Rope Socket / 123

info@peakwellsystems.com | peakwellsystems.com

© 2017 Peak Well Systems Pty Ltd. All rights reserved.



Braided Line Rope Socket

The Braided Line Rope Socket is available for use where high pulling forces are anticipated.

The design incorporates a special one-piece Slip and Initiator Clamp arrangement to ensure maximum line pull can be attained with minimal slippage. A Belleville Spring Stack assembly creates a pre-loaded tension to ensure there is very little movement of the termination during upward and downward jarring.

- APPLICATIONS**
- For use with braided line operations to provide connection of the wireline to the toolstring

- FEATURES AND BENEFITS**
- Incorporates a Peak Heavy-Duty Dual Fish Neck
 - One-piece slip assembly for ease of use
 - Belleville Spring Stack to minimize cable slippage
 - Assembly/disassembly tool provided to aid make up/break out of Slip assembly

TECHNICAL INFORMATION

Actual OD, in	Fish Neck, in
1.500	1.375 / 1.437
1.750	1.375 / 1.437
1.875	1.750 / 1.812
2.125	1.750 / 1.812
2.500	2.313 / 2.375



Product Code: Braided Line Rope Socket / 123

info@peakwellsystems.com | peakwellsystems.com

© 2017 Peak Well Systems Pty Ltd. All rights reserved.



Braided Line Multi-Function Rope Socket

The Braided Line Multi-Function Rope Socket (MFRS) is designed to reduce the overall length of a toolstring by removing the requirement for an extra connection. The integral configuration also ensures that a swivel - a crucial component when using braided line - is always included in the toolstring.

A unique one-piece slip and initiator clamp arrangement ensures maximum line pull can be attained with minimal slippage. A Belleville Washer assembly creates a pre-load tension to ensure there is very little movement of the termination during upward and downward jarring.

APPLICATIONS

- For use with braided line operations

FEATURES AND BENEFITS

- Integral rope socket and swivel: Reduces overall toolstring length and ensures a swivel is incorporated into the braided line toolstring
- One-piece slip and initiator clamp arrangement for ease of use and inventory reduction
- Heavy-duty thrust bearings: Enhance rotation under load
- Integral grease nipple: Allows easy lubrication and prevent corrosion
- Critical components ENP treated to further assist in prevention of internal corrosion
- Assembly/disassembly tool provided for simple cable termination and break out
- Heavy-duty robust design
- Integral Belleville Spring design: Guarantees positive load maintained on thrust bearings to ensure continuous rotation
- Debris rings: Prevent ingress of foreign matter
- Swivel components are supported at rotation point to prevent lateral movement and wear
- Third-party proprietary connections available to suit customer requirements

TECHNICAL INFORMATION

Actual OD, in	Fish Neck, in
1.500	1.375 / 1.437
1.750	1.375 / 1.437
1.875	1.750 / 1.812
2.125	1.750 / 1.812
2.500	2.313 / 2.375



Product Code: Braided Line Multi-Function Rope Socket / 123

info@peakwellsystems.com | peakwellsystems.com

© 2017 Peak Well Systems Pty Ltd. All rights reserved.



Accelerator

The Accelerator is designed to provide a high-controlled impact force when used in conjunction with the Power Jar.

The Accelerator is designed to simulate wire stretch when working at shallow depths in deviated or tortuous wellbores or when working with braided line. The Accelerator is positioned below the rope socket, swivel, or both, and any applied upward tension compresses the Belleville springs providing a source of stored energy and travel for the Power Jar.

As the jar fires, the stored energy accelerates the toolstring, increasing impact on the fish or downhole device to be recovered. The use of an Accelerator also reduces shock loading at the rope socket, swivel, or both

APPLICATIONS

- Improves jar impact
- Reduces shock loading at the rope socket during jarring
- Simulates wire stretch when working at shallow depths to improve jar impact performance

FEATURES AND BENEFITS

- Used for optimum configuration with standard-, medium- or high-load Accelerator set-up options
- Increased stroke length compared with most readily available accelerators improving jar impact
- Equipped with interchangeable Belleville washers
- Simple robust design
- Connection options available to suit customer requirements

TECHNICAL INFORMATION - Power Version

Nominal Size, in	Tool OD, in [mm]	Load Available [†]	Fish Neck, in [mm]
1 ¼	1.250 [31.8]	Standard	1.187 [30.2]
1 ½	1.500 [38.1]		1.375 [34.9]
1 ¾	1.75 [44.4]	Standard, medium, high	1.375 [34.9]
1 ⅞	1.875 [47.6]		1.750 [44.4]
2 ⅛	2.125 [54]		1.750 [44.4]
2 ½	2.500 [63.5]	Standard, high	2.313 [58.8]
2 11/16	2.688 [68.2]		2.375 [60.3]

[†] Various load accelerators are available to suit the operational application.



▲ Accelerator

Product Code: Accelerator / 124

info@peakwellsystems.com | peakwellsystems.com

© 2021 Peak Well Systems Pty Ltd. All rights reserved. Revision: 10th August 2021



Knuckle Joint

The Knuckle Joint, when incorporated into a wireline toolstring, provides flexibility in high angle, deviated wellbores.

The Peak Knuckle Joint incorporates several innovative design features including an integral grease nipple to ensure internal components are continuously lubricated for a prolonged working and storage period. Critical internal components of the Knuckle Joint are also electroless nickel-plated to further assist in prevention of internal corrosion which is common with standard knuckle joints.

APPLICATIONS

- To provide flexibility in a wireline toolstring to assist conveyance in high angle, deviated well bores

FEATURES AND BENEFITS

- Integral grease nipple to ensure easy lubrication and prevent corrosion
- Critical components ENP treated to further assist in prevention of internal corrosion
- Heavy-duty robust design
- Contingent fish neck on most lower joint components
- Third-party proprietary connections available to suit customer requirements

TECHNICAL INFORMATION

Actual OD, in	Fish Neck, in
1.250	1.187
1.500	1.375
1.750	1.375
1.875	1.750
2.125	1.750
2.500	2.313



Product Code: Knuckle Joint / 125

info@peakwellsystems.com | peakwellsystems.com

© 2017 Peak Well Systems Pty Ltd. All rights reserved.



Swivel

The Peak Swivel is designed to allow free rotation of the toolstring and minimize line torque during slickline or cable deployment.

The Swivel can be positioned at any point along the length of the toolstring depending on the application to suit operational requirements. The Swivel incorporates several design features including an integral grease nipple to ensure internal components are continuously lubricated for a prolonged working and storage period. Critical internal components of the Swivel are also electroless nickel-plated to further assist in prevention of internal corrosion which is common with standard swivel joints.

APPLICATIONS

- Predominantly used to provide rotation in a wireline toolstring and minimize line torque
- The Swivel can be utilized to provide a rotating point when handling long or cumbersome tools to aid make up or break out
- The Swivel can also be positioned directly above manipulation tools ie a kick-over tool, to enable an enhanced rotation at depth

FEATURES AND BENEFITS

- Integral grease nipple to ensure easy lubrication and prevent corrosion
- Critical components ENP treated to further assist in prevention of internal corrosion
- Heavy-duty robust design
- Contingent fish neck on most lower joint components
- Third-party proprietary connections available to suit customer requirements

TECHNICAL INFORMATION

Actual OD, in	Fish Neck, in
1.250	1.187
1.500	1.375
1.750	1.375
1.875	1.750
2.125	1.750
2.500	2.313



Product Code: Swivel / 130

info@peakwellsystems.com | peakwellsystems.com

© 2017 Peak Well Systems Pty Ltd. All rights reserved. Revision: 8th April 2014



Bearing Swivel

The Bearing Swivel is designed to allow free rotation of the toolstring and minimize line torque during slickline or cable deployment. The thrust bearing design ensures that the swivel continues to rotate smoothly when subjected to high loads.

The Swivel is generally positioned directly below the rope socket to prevent torque creating an issue with wirelines. The Bearing Swivel incorporates several design features including robust thrust-type bearings with an integral grease nipple to ensure internal components are continuously lubricated for a prolonged working and storage period. Critical internal components of the Swivel are also electroless nickel-plated to further assist in prevention of internal corrosion which is common with standard swivel joints.

APPLICATIONS

- Predominantly used to provide rotation in a wireline toolstring and minimize line torque
- The Swivel can be utilized to provide a rotating point when handling long or cumbersome tools to aid make up or break out
- Ideal for use during swabbing operations where prolonged high loads are encountered

FEATURES AND BENEFITS

- Integral grease nipple: Ensures easy lubrication and prevents corrosion
- Critical components are ENP treated to further assist in the prevention of internal corrosion
- Heavy-duty robust design
- Integral Belleville Spring design guarantees a positive load is maintained on thrust bearings thus ensuring continuous rotation
- Debris Rings: Prevent ingress of foreign matter
- Swivel components are supported at rotation point to prevent lateral movement and wear
- Contingent fish neck on most lower joint components
- Third-party proprietary connections available to suit customer requirements

TECHNICAL INFORMATION

Actual OD, in	Fish Neck, in
1.500	1.375
1.750	1.375
1.875	1.750
2.125	1.750
2.500	2.313



Product Code: Bearing Swivel / 130

info@peakwellsystems.com | peakwellsystems.com

© 2017 Peak Well Systems Pty Ltd. All rights reserved. Revision: 8th April 2014



Stem

Stem provides weight/mass to the toolstring to enable the wire to run into the well against pressure and friction.

Stem weight also assists upward and downward jarring impact in conjunction with a mechanical type jar. Made from the highest quality material, Peak Slickline Stem is available in various lengths, diameters and connection options to suit standard and non-standard operations.

APPLICATIONS

- To provide weight/mass to the toolstring
- To enable the wire to run into the well against pressure and friction
- To provide extension length for diagnostic or space-out purposes

FEATURES AND BENEFITS

- Supplied with industry standard connections and also third-party proprietary connections to suit customer requirements
- Stem supplied in standard lengths and diameters
- Special sizes available on request to suit customer requirements

TECHNICAL INFORMATION

Actual OD, in	Length, ft	Fish Neck, in
1.250	2, 3, 5	1.187
1.500	2, 3, 5	1.375
1.750	2, 3, 5	1.375
1.875	2, 3, 5	1.750
2.125	2, 3, 5	1.750
2.500	2, 3, 5	2.313



Product Code: Stem / 102

info@peakwellsystems.com | peakwellsystems.com

© 2017 Peak Well Systems Pty Ltd. All rights reserved.



Tungsten Stem

Peak Tungsten Stem is primarily used to substitute standard stem in higher pressure applications to enable the wire or cable to run into the well against pressure and friction.

The Peak Tungsten Stem can also be utilized during flowing gradient surveys to provide extra weight/mass to the toolstring to reduce tool lift. The stem weight also assists upward and downward jarring impact in conjunction with a mechanical type jar as well as allowing shorter toolstrings in height-restricted applications due to the increased weight per foot.

Made from the highest quality material, Peak Tungsten Stem is available in various lengths, diameters and connection options to suit standard and non-standard operations.

APPLICATIONS

- Utilized as a substitute to standard stem for additional weight in higher pressure applications to enable the wire to run into the well against pressure and friction
- Provides extra weight to reduce tool lift during flowing gradient surveys
- Increased weight per foot enables shorter toolstrings in height-restricted applications

FEATURES AND BENEFITS

- Supplied with industry standard connections and also third-party proprietary connections to suit customer requirements
- Unique securing mechanism ensures prevention of internal movement of tungsten rod
- Stem supplied in standard lengths and diameters
- Special sizes available on request to suit customer requirements

TECHNICAL INFORMATION

Actual OD, in	Length, ft	Weight, lbr
1.500	3	24.5
1.500	5	43.5
1.875	3	38.0
1.875	5	67.5
2.125	3	49.0
2.125	5	88.0
2.500	3	64.5
2.500	5	114.5



Product Code: Tungsten Stem / 144

info@peakwellsystems.com | peakwellsystems.com

© 2017 Peak Well Systems Pty Ltd. All rights reserved.



Pump Down Stem

The Peak Pump Down Stem is designed to configure to a standard slickline toolstring to combat the difficulty of getting to depth in highly deviated wells.

The Pump Down Stem design incorporates cup-type elements that provide an increased surface area to pump the toolstring into the well. The Stem can be run with one, two or no cups as required.

APPLICATIONS

- Conveying a toolstring to target depth

FEATURES AND BENEFITS

- Simple design
- Multiple running configurations
- Large surface area to tool weight
- Minimize wireline runs
- Interchangeable components
- Connection options and sizes available to suit customer requirements



Product Code: Pump Down Stem / 102

info@peakwellsystems.com | peakwellsystems.com

© 2017 Peak Well Systems Pty Ltd. All rights reserved.

peak 
WELL SYSTEMS

Modular Drop Bar System (Go-Devil)

The Modular Drop Bar System is a series of interchangeable components designed to increase operational flexibility when there is a requirement for deploying a Drop Bar/Go-Devil to activate an Interface-type Cutter Bar.

The variable Drop Bar length and Bottom Sub options cover most wellbore geometries and downhole conditions. The Peak design also provides the option of incorporating the Peak Fluted Slip-Over and Slip-Over Roller Centralizers when deploying in larger bore or high-angle wells.

APPLICATIONS

- For activating Cutter Bars
- Providing a solid base to enable deployment of Cutter Bar
- Can be deployed to regain mechanical jar action if lost

FEATURES AND BENEFITS

- Can be deployed as a 2-ft, 3-ft, or 5-ft section to suit operational application
- Can be used using the Flat Bottom or Mule Bottom Sub options to suit operational application
- Optional Fluted Slip-Over or Slip-Over Roller Centralizer options for deploying in larger bore or high-angle wells
- Suits multiple line sizes up to 5/16-in diameter
- Inventory reduction due to the unique modular design

TECHNICAL INFORMATION

Actual OD, in	Configuration Length Options, ft	To Suit Wire Size, in
1.500	2, 3 or 5	0.092 to 0.312
1.875	2, 3 or 5	0.092 to 0.312
2.187	2, 3 or 5	0.092 to 0.312



Product Code: Modular Drop Bar System (Go-Devil) / 122

info@peakwellsystems.com | peakwellsystems.com

© 2017 Peak Well Systems Pty Ltd. All rights reserved.



Power Jar

The Power Jar is a high-performance, fully adjustable spring jar with a unique inverted upstroke feature, which has been developed out of necessity to ensure performance continuity in high-debris environments.

Compared with standard spring jars, the internal workings of the Power Jar are located in the upper section of the assembly. This ensures minimal debris influx during upstroke and any debris that has entered the outer housing simply falls to the bottom of the tube, away from the critical working components.

APPLICATIONS

- High angle, standard wireline, or wireline fishing operations

FEATURES AND BENEFITS

- Increased performance in high-debris environments enabled by inverted latch and jar rod, which significantly reduces debris influx
- Improved impact force and reduced amount of stem due to increased mass above the jar rod
- Adjustable on-toolstring and precise jar setting while in hole enabled by opposable button locking mechanism
- Amplified effective impact force, particularly in deviated wells, and near frictionless jar stroke enabled by Peak Integral Dual Roller System
- Reduced cost due to minimal working parts, resulting in simple and rapid redress
- Controlled impact at lower jar settings due to dual spring stack
- Increased component working life and reduced cost due to Spring Stack permanently relaxed and compressed only during firing operation
- Supplied with connection options to suit customer requirements
- Aligned with Peak's Accelerator, Linear Jar and WellGlide® roller-centralizer sub for effective conveyance and performance in high-angle, deviated wells
- Universal Hydraulic Calibration Sub suitable for a range of Power Jars sizes and all connection types

TECHNICAL INFORMATION

Tool OD, in [mm]	Standard Fish Neck, in [mm]	Stroke, in [cm]	Setting Range, lbm
1.500 [38.1]	1.375 [34.9]	8.0 [20.3]	200 - 600
1.750 [44.4]		10.6 [26.9]	300 - 1,250
1.875 [47.6]	1.750 [44.4]	10.7 [27.1]	300 - 1,250
2.125 [54]		10.0 [25.4]	400 - 3,000
2.500 [63.5]	2.313 [58.8]	12.0 [30.4]	600 - 4,000
2.688 [68.2]	2.375 [60.3]	14.0 [35.5]	1,500 - 7,000



▲ Hydraulic Calibration Sub



▲ All standard industry connections available

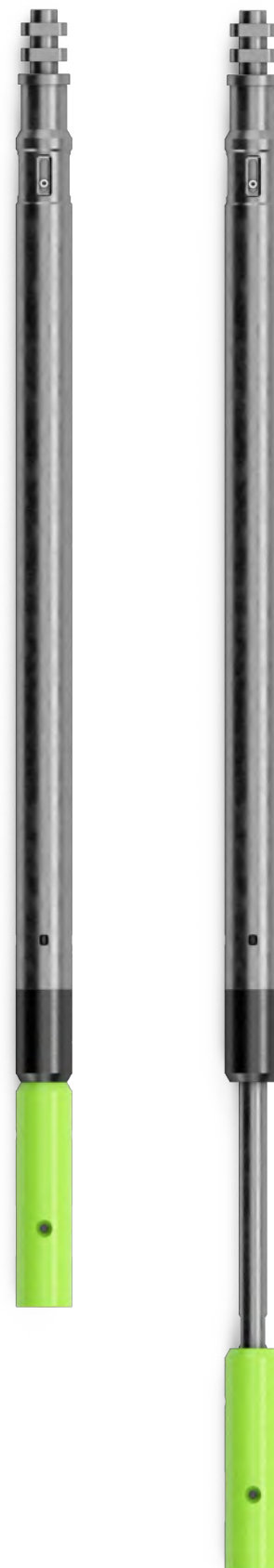

▲ Power Jar in closed (left), open (right) states



*Mark of Schlumberger

Product Code: Power Jar / 220

info@peakwellsystems.com | peakwellsystems.com

© 2021 Peak Well Systems Pty Ltd. All rights reserved. Revision: 10th August 2021

Hydraulic Jar

High-performance tool for high-angle operations, with a unique inverted upstroke enabling performance continuity in high-debris environments.

The Peak Hydraulic Jar minimizes debris influx on the upstroke because its internal components are in the upper section of the assembly—unlike standard hydraulic jars. Also, any debris that enters the outer housing simply falls to the bottom of the tube and away from critical working components.

APPLICATIONS

- High angle standard wireline, or wireline fishing operations
- High debris environments
- High temperature wells

FEATURES AND BENEFITS

- Reduces debris influx and increases performance in high-debris environments by inverting the latch and jar rod design
- Improves impact force and reduces stem spacing requirement because of its increased mass above the jar rod
- Simplifies and expedites redress with minimal working parts
- Minimizes internal corrosion risks with hard chrome plating on critical components
- Ensures consistency and accuracy of firing times with Lee Chek® and Lee Jeva® (check and restrictor) valves
- Provides flexibility for application requirements with multiple connection options
- Excels in high temperature wells up to 392 degF [200 degC]
- Extends reach and performance in high-angle deviated wells by combining with Peak Accelerator, Peak Linear Jar, and WellGlide® roller-centralizer sub.

TECHNICAL INFORMATION

Tool OD, in [mm]	Standard Fish Neck, in [mm]	Jar Range, lbf [N]
1.750 [44.45]	1.375 [34.925]	500–3,000 [2,224–17,793]
1.875 [47.625]	1.750 [44.45]	500–3,000 [2,224–17,793]
2.125 [53.975]	1.750 [44.45]	500–3,000 [2,224–17,793]
2.500 [63.5]	2.313 [79.5]	500–4,000 [2,224–17,793]



*Mark of SLB

Product Code: Hydraulic Jar / 147

info@peakwellsystems.com | peakwellsystems.com

© 2023 Peak Well Systems Pty Ltd. All rights reserved. Revision: 2 February 2023



Hydraulic Calibration Sub

The Hydraulic Calibration Sub allows rapid and accurate set up of the Power Jar prior to deployment.

The Hydraulic Calibration Sub is easily made up to the jar by sliding the sub over the lower end and by simply inserting the punch and split guide ring. The handle can then be turned to open the jar at the predetermined setting required. With a 1:1 setting ratio, the hydraulic gauge displays the actual release force expected downhole.

APPLICATIONS

- Directly calibrates the Power Jar for downhole use

FEATURES AND BENEFITS

- One Calibration Sub suits all connection types
- Removal of integral threaded jar subs not required
- Direct 1:1 setting ratio
- Quick and easy Power Jar set-up
- Inventory reduction
- Robust design



▲ Hydraulic Calibration Sub with Power Jar

Product Code: Hydraulic Calibration Sub / 221

info@peakwellsystems.com | peakwellsystems.com

© 2021 Peak Well Systems Pty Ltd. All rights reserved. Revision: 10th August 2021

peak 
WELL SYSTEMS

Spang Jar

The Spang Jar generates impact force required downhole to manipulate tools and sever shear pins.

Jar impact is mainly affected by speed of movement, applied stem weight above the jar, stroke length, and deviation. Peak Spang Jars are available in various stroke lengths, diameters, and connection options to suit the customers requirements.

APPLICATIONS

- Provide upward and downward impact in conjunction with the toolstring weight and wireline speed

FEATURES AND BENEFITS

- Supplied in a range of sizes and stroke lengths to suit most application
- Offered with available third-party proprietary connections to suit customer requirements

TECHNICAL INFORMATION

Tool OD, in [mm]	Stroke, in [cm]	Fish Neck, in [mm]
1.250 [31.8]	20 [50.8] or 30 [76.2]	1.187 [30.1]
1.500 [38.1]	20 [50.8] or 30 [76.2]	1.375 [34.9]
1.750 [44.4]	20 [50.8] or 30 [76.2]	1.375 [34.9]
1.875 [47.6]	20 [50.8] or 30 [76.2]	1.750 [44.4]
2.125 [54]	20 [50.8] or 30 [76.2]	1.750 [44.4]
2.500 [63.5]	20 [50.8] or 30 [76.2]	2.313 [58.8]



▲ Spang Jar in closed (left), open (right) states.

Product Code: Spang Jar / 127

info@peakwellsystems.com | peakwellsystems.com

© 2021 Peak Well Systems Pty Ltd. All rights reserved. Revision: 10th August 2021



Tubular Jar

The Tubular Jar is a simple yet effective mechanical-type jar designed for use during operations where there is a potential for debris ingress that may prevent critical jar manipulation.

APPLICATIONS

- Ideal during fishing operations when the design of standard spang jars can be impeded by wire, debris, or other foreign matter in the tubing
- Deployed inside large ID tubing or casing where conventional spang jars are prone to buckling or scissoring

FEATURES AND BENEFITS

- Improved diameter in jar rod
- Increased mass above jar rod reduces amount of stem required above, which ultimately reduces toolstring length
- Supplied with connection options to suit customer requirements
- Effectively carries out fishing operations in wellbores with suspected wire, debris or other foreign matter
- Robust design for effective routine wireline functions in large tubing or casing

TECHNICAL INFORMATION

Actual OD, in [mm]	Stroke, in [cm]	Fish Neck, in [mm]
1.250 [31.8]	20 [50.8]	1.187 [30.2]
1.500 [38.1]	20 [50.8] or 30 [76.2]	1.375 [34.9]
1.750 [44.4]	20 [50.8] or 30 [76.2]	
1.875 [47.6]	20 [50.8] or 30 [76.2]	1.750 [44.4]
2.125 [54]	20 [50.8] or 30 [76.2]	
2.500 [63.5]	20 [50.8] or 30 [76.2]	2.313 [58.8]



▲ Tubular Jar in closed (left), open (right) states.

Product Code: Tubular Jar / 126

info@peakwellsystems.com | peakwellsystems.com

© 2021 Peak Well Systems Pty Ltd. All rights reserved. Revision: 10th August 2021



Linear Jar

The Linear Jar is ideal for use in high-angle wells where normal spang (link-type) or tubular jar action may be limited.

The unique dual-roller system from Peak Well Systems reduces friction between the jar rod and outer housing. The resulting smooth bidirectional strokes drive upward and downward forces to power most routine wireline functions in deviated wellbores.

To further improve the overall friction-reducing performance, the Linear Jar also works with the Power Jar (an inverted upstroke spring jar), WellGlide® roller-centralizer sub, and eWellGlide® through-wired roller-centralizer sub.

APPLICATIONS

- Wireline operations in high angle, deviated wells
- Fishing operations in suspected wire, debris, or other foreign-matter environments
- Large-ID tubing or casing operations
- Combined operations with the Power Jar (inverted upstroke spring jar) for improved overall friction-reducing performance

FEATURES AND BENEFITS

- Smooth bidirectional stroke produced by unique dual-roller system for enabling most routine wireline functions in high-angle deviated wellbores
- Improved durability because of increased jar rod diameter
- Range of connection options that meet customer requirements
- Improved overall friction-reducing performance in combination with the Power Jar (inverted upstroke spring jar)
- Outperformance over standard spang jars for fishing operations in wellbores with suspected wire, debris, or other foreign matter
- Robust design for conducting routine wireline functions in large-diameter tubing or casing, where conventional spang jars are prone to buckling or scissoring

TECHNICAL INFORMATION

Actual OD, in [mm]	Stroke, in [cm]	Fish Neck, in [mm]
1.750 [44.4]	20 [50.8] or 24 [61]	1.375 [35]
1.875 [47.6]	20 [50.8] or 24 [61]	1.750 [44.4]
2.125 [54]	20 [50.8] or 24 [61]	
2.500 [63.5]	20 [50.8] or 24 [61]	2.313 [58.8]



▲ Linear Jar in closed (left), open (right) states



*Mark of Schlumberger

Product Code: Linear Jar / 120

info@peakwellsystems.com | peakwellsystems.com

© 2021 Peak Well Systems Pty Ltd. All rights reserved. Revision: 17 August 2021

Crossover

The Peak Crossover is designed to connect two toolstring items with different connections.

Manufactured from the highest quality material, Peak can supply a complete range of Crossovers to suit most readily available connection types.

APPLICATIONS

- To provide a connection between two toolstring items with different connections

FEATURES AND BENEFITS

- Supplied with industry standard crossover configurations
- Crossovers supplied in both standard and special lengths and diameters to suit operational requirements
- Crossovers can be supplied with third-party proprietary connections to suit customer requirements

TECHNICAL INFORMATION

Actual OD, in	Pin Connection	Box Connection	Fish Neck, in
1.875	15/16-in SR	1 1/16-in SR	1.375
1.875	1 1/16-in SR	15/16-in SR	1.750
2.125	15/16-in SR	1 1/16-in SR	1.375
2.125	1 1/16-in SR	15/16-in SR	1.750
2.500	15/16-in SR	1 9/16-in SR	1.375
2.500	1 1/16-in SR	1 9/16-in SR	1.750
2.500	1 9/16-in SR	15/16-in SR	2.313
2.500	1 9/16-in SR	1 1/16-in SR	2.313

Actual OD, in	Pin Connection	Pin Connection	Fish Neck, in
1.500	15/16-in SR	15/16-in SR	1.375
1.875	1 1/16-in SR	1 1/16-in SR	1.750
2.125	1 1/16-in SR	1 1/16-in SR	1.750
2.500	1 9/16-in SR	1 9/16-in SR	2.313

Actual OD, in	Box Connection	Box Connection	Fish Neck, in
1.500	15/16-in SR	15/16-in SR	1.375
1.875	1 1/16-in SR	1 1/16-in SR	1.750
2.125	1/16-in SR	1 1/16-in SR	1.750
2.500	1 9/16-in SR	1 9/16-in SR	2.313



▲ Peak Combination Wire Scratcher shown with Sucker Rod Crossover

Product Code: Crossover / 101

info@peakwellsystems.com | peakwellsystems.com

© 2017 Peak Well Systems Pty Ltd. All rights reserved.



Quick Connect (QC)

The Peak Quick Connect (QC) is a simple and effective wireline tool quick connection that offers a vast range of benefits versus sucker rod type threaded connections when supplied integral to tooling components.

APPLICATIONS

- Designed to simply and quickly connect two wireline tool components, the Peak QC can be incorporated into most wireline tool and toolstring assemblies and is proven to increase efficiency and performance with improved strength and added safety

FEATURES AND BENEFITS

- 100% compatible with the industry standard QLS connection
- Robust design with an increased tensile strength compared to equivalent sucker rod connections
- Rapid make up and break out of toolstrings - around four times faster than sucker rod connections
- Peak QC cannot be released downhole unlike sucker rod connections
- Minimal moving components with a simple one-piece laser cut Locking Plate and Spring arrangement
- No small buttons, springs, circlips or pins making redress simpler, faster and more cost effective than other types of quick connections
- Peak QC components last longer than sucker rod threads which can stretch and weaken whilst pipe wrench marks permanently damage and deform wireline tools

SAFETY

- No pipe wrenches required = no strains, cuts from burrs, upper body or facial injuries due to slipping pipe wrenches
- Reduced exposure to making up and breaking out connections ultimately reducing potential for harm
- Breaking out tools at height eg semi-submersible operations are safer, quicker and easier with the Peak QC due to less time spent in man-riding harnesses, no heavy or cumbersome pipe wrench use required at height, and only one person required to make up or break out reducing exposure to potential harm

TECHNICAL INFORMATION

Nominal Peak QC, in	Actual OD, in	Fish Neck Option (Standard & Peak HD), in	Connection Yield Strength with 1:2 Factor of Safety, lbm
1 1/2	1.500	1.375 / 1.437	49,718
1 7/8	1.875	1.750 / 1.812	76,783
1 7/8	2.125	1.750 / 1.812	76,783
2 1/2	2.500	2.313 / 2.375	125,404



Product Code: Quick Connect / 121

info@peakwellsystems.com | peakwellsystems.com

© 2017 Peak Well Systems Pty Ltd. All rights reserved.



Ultra-Heavy-Duty Multi-Function Shear Pin Rope Socket

The Ultra-Heavy-Duty (UHD) Multi-Function Shear Pin Rope Socket has been manufactured for use where high pulling forces are anticipated.

A unique one-piece Slip and Initiator Clamp arrangement ensures maximum line pull can be attained with minimal slippage. A Belleville Washer assembly creates a pre-load tension to ensure there is very little movement of the termination during upward and downward jarring. The UHD Multi-Function Shear Pin Rope Socket is a combination Rope Socket and Swivel designed to reduce the overall length of the toolstring by removing the requirement for an extra connection.

The integral configuration also ensures that a swivel, a crucial component when using braided line, is always included in the toolstring. The Multi Shear Pin Release Sub allows the cable and upper rope socket assembly to be recovered should the toolstring become stuck, leaving a clean heavy-duty fish neck that can be recovered using the Heavy-Duty Full Radial Contact (HD FRC) Pulling Tool.

APPLICATIONS

- For use with ultra-heavy-duty braided line operations

FEATURES AND BENEFITS

- Integral Rope Socket & Swivel: Reduces overall toolstring length and ensures a swivel is incorporated into the braided line toolstring
- One-piece Slip and Initiator Clamp arrangement for ease of use and inventory reduction
- Integral primary and contingent Peak Heavy-Duty Fish Neck which has a 60% increased load bearing area compared to standard fish necks, improving overall strength
- Multi Shear Pin options to suit operational application for mechanical release
- Heavy-Duty Tapered Roller Bearings: Enhance rotation under load
- Integral Grease Nipple: Allows easy lubrication and prevents corrosion
- Critical components ENP treated to further assist in prevention of internal corrosion
- Assembly/disassembly tool provided for simple cable termination and break out
- Supplied with Peak 2 11/16-in UHD QC connection



Product Code: Ultra-Heavy-Duty Multi-Function Shear Pin Rope Socket / 123

info@peakwellsystems.com | peakwellsystems.com

© 2017 Peak Well Systems Pty Ltd. All rights reserved.

peak 
WELL SYSTEMS

Ultra-Heavy-Duty Accelerator

The Ultra-Heavy-Duty (UHD) Accelerator is designed to be run in tandem with an identical UHD Accelerator to provide a high, controlled, impact force when used in conjunction with the Peak Power Jar.

The unique 'over-stress limiting' feature is guaranteed to generate velocity for impact that is consistent, continuous and performs under extreme conditions during prolonged periods of jarring. Whilst reducing shock loading at the Rope Socket/Swivel, the Peak UHD Accelerator is also designed to simulate wire stretch when working at shallow depths, in deviated or tortuous wellbores, or when working with braided line.

The Accelerator is positioned below the Rope Socket/Swivel and any applied upward tension compresses the Belleville Springs whilst extending the ultimate Accelerator stroke length. As the jar fires, the stored energy accelerates the toolstring increasing impact on the fish or downhole device to be recovered.

APPLICATIONS

- For use with ultra-heavy-duty braided line operations

FEATURES AND BENEFITS

- Unique 'over-stress limiting' feature dramatically increases the working life of the Belleville Washer configuration and accelerator components by preventing excessive stress on critical parts
- Unique 'over-stress limiting' feature provides a consistently high impact without performance deterioration when used in conjunction with the UHD Power Jar
- Unique 'over-stress limiting' feature removes 'in-operation' redress time and cost commonly associated and required with standard accelerators
- Optimum usage configuration with standard or high load accelerator set-up options
- Increased stroke length compared to most readily available accelerators improving jar impact
- Integral primary and contingent Peak HD Fish Necks on all components which have a 60% increased load bearing area compared to standard fish necks, improving overall strength
- Interchangeable Belleville Washers
- Supplied with Peak 2 11/16-in UHD QC connections



Product Code: Ultra-Heavy-Duty Accelerator / 124

info@peakwellsystems.com | peakwellsystems.com

© 2017 Peak Well Systems Pty Ltd. All rights reserved.

peak 
WELL SYSTEMS

Ultra-Heavy-Duty Knuckle Joint

The Ultra-Heavy-Duty (UHD) Knuckle Joint, when incorporated into a wireline toolstring, provides flexibility in high-angle, deviated wellbores.

The UHD Knuckle Joint incorporates several design features including integral grease nipple to ensure internal components are continuously lubricated for a prolonged working and storage period. Critical internal components of the UHD Knuckle Joint are also electroless nickel-plated to further assist in prevention of internal corrosion which is common with standard knuckle joints.

APPLICATIONS

- To provide flexibility in a wireline toolstring; assisting conveyance in high angle, deviated wellbores

FEATURES AND BENEFITS

- Integral grease nipple to ensure easy lubrication and prevent corrosion
- Critical components are ENP treated to further assist in prevention of internal corrosion
- Integral primary and contingent Peak HD Fish Necks on all components which have a 60% increased load bearing area compared to standard fish necks, improving overall strength
- Supplied with Peak 2 11/16-in UHD QC connections



Product Code: Ultra-Heavy-Duty Knuckle Joint / 125

info@peakwellsystems.com | peakwellsystems.com

© 2017 Peak Well Systems Pty Ltd. All rights reserved.

peak 
WELL SYSTEMS

Ultra-Heavy-Duty Power Jar

The Ultra-Heavy-Duty (UHD) Power Jar is a high performance, fully adjustable spring jar with a unique inverted upstroke feature which has been developed out of necessity to ensure performance continuity in high debris environments.

Compared to standard spring jars, the internal workings of the UHD Power Jar are located in the upper section of the assembly. This ensures very little debris influx during upstroke and any debris that has entered the outer housing simply falls to the bottom of the tube, away from the critical working components.

APPLICATIONS

- For use with ultra-heavy-duty braided line operations

FEATURES AND BENEFITS

- Inverted latch and jar rod reduces debris influx, significantly increasing performance in high debris environments
- Increased mass above jar rod improves impact force whilst reducing the amount of stem required above
- Opposable button locking mechanism enables 'on toolstring' adjustment and maintains precise jar setting whilst in hole
- Peak Integral Dual Roller System is designed to enable a near frictionless jar stroke that increases effective impact force particularly in high-angle, deviated wells
- Minimal working parts result in simple and rapid redress with ultimate reduction in cost
- Spring stack permanently relaxed, and compressed only during firing operation thus increasing component working life and reducing cost
- Universal Hydraulic Calibration Sub to suit all connection types
- Critical components are ENP treated to further assist in the prevention of internal corrosion
- Supplied with 2 11/16-in UHD QC connection



Product Code: Ultra-Heavy-Duty Power Jar / 220

info@peakwellsystems.com | peakwellsystems.com

© 2017 Peak Well Systems Pty Ltd. All rights reserved.

peak 
WELL SYSTEMS

Ultra-Heavy-Duty Linear Jar

The Ultra-Heavy-Duty (UHD) Linear Jar is designed to operate at high angles where normal tubular jar action may be limited.

The Peak Dual Roller System reduces friction between the jar rod and outer housing allowing a smooth bi-directional stroke to effectively impart sufficient upward and downward force to carry out most routine wireline functions in deviated wellbores. The UHD Linear Jar is specifically designed for use with braided line work where line speed is often minimal, and in conjunction with the UHD Power Jar and Peak's WellGlide for improved overall friction reducing performance during heavy-duty fishing operations.

APPLICATIONS

- For use with ultra-heavy-duty braided line operations
- For use in high-angle, deviated wells to enable a smooth bi-directional stroke to effectively carry out routine wireline and heavy-duty braided line fishing operations
- Ideal for use during fishing operations, when the design of standard spang jars could be impeded by wire, debris or other foreign matter in the tubing
- Designed for use in conjunction with the UHD Power Jar and Peak's WellGlide for improved overall friction reducing performance

FEATURES AND BENEFITS

- Peak Integral Dual Roller System designed to enable a near frictionless jar stroke to increase effective impact force particularly in high-angle, deviated wells
- Supplied with Peak 2 11/16-in UHD QC connections



Product Code: Ultra-Heavy-Duty Linear Jar / 120

info@peakwellsystems.com | peakwellsystems.com

© 2017 Peak Well Systems Pty Ltd. All rights reserved.

peak 
WELL SYSTEMS

Safe Enclosed Pull Test Sub

The Peak Safe Enclosed Pull Test Sub is a simple and effective device to increase safety and improve current and potentially dangerous methods of pull testing braided line rope sockets prior to deployment.

Apart from ensuring the rope socket integrity, the pull test ensures that the winch is secured correctly and that sheaves and other securing/lifting attachments are fit for sustaining heavy loads or impact. The Peak design allows the pull test to be carried out fully contained within the lubricator. If the cable or tools part during the pull test, personnel would not be harmed and the equipment is unlikely to sustain damage as it is protected within the pressure control equipment.

The main body is made up to the interchangeable plate to suit the specific quick union which is then connected to the toolstring. The lubricator can then be lowered with the Sub inserted between both mating quick unions. The lubricator collar would then be made up to the BOP and tension can be taken up and the pull taken on the cable to 'bed in' the slips of the Rope Socket and test all attachments.

APPLICATIONS

- Safe pull testing

FEATURES AND BENEFITS

- Eliminates external pull testing thereby greatly improving safety
- Supplied with connection options to suit any wireline toolstring
- Interchangeable plates to suit any PCE quick union for inventory reduction
- Can be used with all braided cables up to 5/16-in diameter
- SWL for all sizes is rated to 10,000 lbm



Product Code: Safe Enclosed Pull Test Sub / 904

info@peakwellsystems.com | peakwellsystems.com

© 2017 Peak Well Systems Pty Ltd. All rights reserved.

peak 
WELL SYSTEMS

Gauge Cutter

The Gauge Cutter is predominantly used for drifting the tubing string but is also designed to remove scale, debris, and paraffin wax etc.

Reaching target depth with the Gauge Cutter confirms that the tubing string is clear prior to performing more complex tasks such as recovering or installing flow control devices.

APPLICATIONS

- Predominantly used for drifting the tubing but also designed to remove scale, debris, and paraffin wax etc.

FEATURES AND BENEFITS

- Supplied in a range of sizes - various lengths and diameters available on request
- Saw Tooth design available on request
- Tapered design available on request



Product Code: Gauge Cutter / 117

info@peakwellsystems.com | peakwellsystems.com

© 2017 Peak Well Systems Pty Ltd. All rights reserved.

peak 
WELL SYSTEMS

Blind Box

The Peak Blind Box is used to dislodge or push tools down the wellbore and consists of a simple one-piece design made from the highest quality material.

The Blind Box is generally used when heavy downward jarring is required to clear an obstruction, dislodge a stuck fish, or sever wireline at the rope socket when a toolstring is stuck or wire has parted downhole. The solid full bore design also allows the Blind Box to be used to locate the fluid level in a wellbore.

APPLICATIONS

- Can be used to clear an obstruction or to dislodge a stuck fish
- Sever wireline at the rope socket when a toolstring is stuck or wire has parted downhole
- Can be used to locate the fluid level in the wellbore

FEATURES AND BENEFITS

- One-piece, solid design
- Connection options available to suit customer requirements
- Tapered designs available



Product Code: Blind Box / 104

info@peakwellsystems.com | peakwellsystems.com

© 2017 Peak Well Systems Pty Ltd. All rights reserved.

peak 
WELL SYSTEMS

Combination Gauge Ring and Wire Scratcher

The Combination Gauge Ring and Wire Scratcher is a flexible system designed to drift the well and brush a specific area within the tubing in a single run.

The interchangeable Gauge Cutter Rings allow the system to be utilized across a range of tubing sizes that will save the customer significant time and ultimately cost by removing unnecessary wireline runs.

APPLICATIONS

- Designed to drift the well and brush a specific area in a single run
- Can be used as a traditional Gauge Cutter when the Wire Scratcher is not required

FEATURES AND BENEFITS

- Combined design of Gauge Cutter and Wire Scratcher reduces wireline runs therefore reducing time and cost
- Interchangeable Gauge Cutter Rings provide flexibility to suit a range of tubing sizes
- Ported Gauge Cutter Rings provide sufficient bypass in fluid
- Positive stop prevents Gauge Cutter Ring from backing off from the Mandrel
- Minimal components and robust design
- Inventory reduction

TECHNICAL INFORMATION

Nominal Mandrel Size, in	Gauge Ring Range, in	To Suit Wire Size (Brush), in
1 1/2	2.375 - 3.950	Up to 7/32
1 7/8	2.750 - 5.500	Up to 5/16
2 1/2	2.750 - 8.500	Up to 5/16



Product Code: Combination Gauge Ring and Wire Scratcher / 113

info@peakwellsystems.com | peakwellsystems.com

© 2017 Peak Well Systems Pty Ltd. All rights reserved.



FlexiDrift

The fully adjustable Peak FlexiDrift offers the ultimate in flexibility, accuracy and reliability providing a full range of drift coverage with minimal inventory.

Deployed on slickline and all other standard industry conveyance methods, the FlexiDrift consists of a mandrel with two sets of adjustable rails that can be manually extended with ease using the adjustment sleeves to the desired radius of the well tubing.

When run downhole, the unique positioning of the extended rails provides the highest radial contact across the widest operating range of required drift sizes to confirm the minimum diameter specification of well bore tubing whilst ensuring no unforeseen obstructions, debris or damage is present in the well prior to other operations.

The FlexiDrift's unique design allows for sufficient bypass of fluid like any fluted centralizer drift; and is available in three standard tool sizes that can be accurately adjusted to within 10 thousandths of the desired diameter to span drift diameters of 2.000-in to 2.750-in, 2.720-in to 3.750-in, and 3.700-in to 5.750-in respectively. Upwards jarring will activate the shear release function to retract the FlexiDrift to the minimum size, to allow for reliable retrieval to surface in the event of becoming stuck downhole.

APPLICATIONS

- Ensures no unforeseen obstructions in the well prior to well intervention
- Verification of well ID
- Tool centralization

FEATURES AND BENEFITS

- Simple to use: Easily adjustable at well site to within 10 thou of desired diameter
- Better extension range: Provides the highest radial contact across the widest operating range of required drift sizes
- Robust design: Can be run multiple times for multiple applications
- Reduced inventory: Available in three standard tool sizes to suit drift diameters ranging from 2.000-in to 5.750-in
- Reliable retrieval: Emergency shear out function allows drift to collapse to minimum ID by jarring up - even in high deviation wells and those with a high level of scale or debris
- Fully field redressable
- Can be supplied in all standard industry connection types
- Allows for bypass of fluid

TECHNICAL INFORMATION

Actual OD, in	Range of Coverage, in	Length of Tool, in
2.000	2.000 – 2.750	29.76
2.720	2.720 – 3.750	33.15
3.700	3.700 – 5.750	43.27

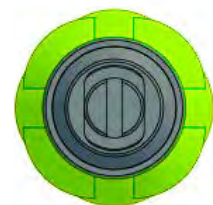

Product Code: FlexiDrift / 153

info@peakwellsystems.com | peakwellsystems.com

© 2017 Peak Well Systems Pty Ltd. All rights reserved. Revision: 26th June 2015



Bore-Sensing Drift

The fully adjustable Peak Bore-Sensing Drift offers the ultimate in flexibility, accuracy and reliability, providing a full range of drift coverage with minimal inventory.

Deployed on slickline and all standard conveyance methods, the Bore-Sensing Drift features two sets of keys that collapse to pass any restriction in the well tubing.

When run downhole, the positioning of the keys provide full-radial coverage of obstructions, debris, or damage in the wellbore. The keys remain collapsed and on recovery to surface they can be measured to determine the minimum ID of the well tubing.

The Bore-Sensing Drift's design allows for sufficient bypass of fluid similar to most fluted centralizer drifts.

APPLICATIONS

- Drifting wells before intervention runs to measure actual minimum ID in the path to target depth

FEATURES AND BENEFITS

- Simple to use: keys can be adjusted easily at the wellsite
- Robust design: can be run multiple times
- Flexible: can be supplied in all standard industry connection types
- Reduced inventory: one tool covers a wellbore ID measuring range of 2.300 in to 1.900 in
- Cost-effective: minimal working parts result in simple and rapid redress in the field

TECHNICAL INFORMATION

Nominal tubing size, in	Max. Tool OD, in	Bore ID Measuring Range, in	Diametrical Resolution OD [†] , in [mm]	Length, in [m]	Weight, lbm [kg]	Fish Neck, in
2 7/8	1.800	2.300-1.900	±0.040 [±1.00]	31.5 [0.8]	16.5 [7.5]	1.375

[†] Custom higher resolution options are available on request



▲ Peak Bore-Sensing Drift

Product Code: Bore-Sensing Drift / 153

info@peakwellsystems.com | peakwellsystems.com

© 2021 Peak Well Systems Pty Ltd. All rights reserved. Revision: 17th March 2021



GS Pulling Tool

The GS style Pulling Tool is designed to latch and recover downhole products that have a standard internal fishing neck.

The tools include a safety feature of 'jar down to release' and a unique and safer surface release mechanism on the larger sizes.

APPLICATIONS

- Routine slickline operations
- Wireline fishing

FEATURES AND BENEFITS

- Robust design
- Individual retractable dogs
- Unique helical slot for easy punch release
- Available with standard and quick connect toolstring connections

TECHNICAL INFORMATION

Nominal Tubing Size, in	Nominal GS Designation, in	Actual Tool OD, in	Core Thread, in
2 3/8	2	1.750	5/8 - 11 UNC
2 7/8	2.5	2.250	5/8 - 11 UNC
3 1/2	3	2.720	5/8 - 11 UNC
4	3.5	3.110	1 3/8 - 12 UN
4 1/2	4	3.620	2 1/8 - 12 UN
5 1/2	5	4.500	2 1/2 - 10 UN
7	6	5.560	2 3/4 - 10 UN
7	7	5.875	3 5/8 - 10 UN



Product Code: GS Pulling Tool / 229

info@peakwellsystems.com | peakwellsystems.com

© 2017 Peak Well Systems Pty Ltd. All rights reserved.



eMAT/GS Tool

Peak's eMAT/GS Tool is used to replicate traditional GS functionality on slickline during e-line deployments.

The eMAT/GS Tool provides a reliable deployment technique without the need for pyrotechnics, pressurized nitrogen or downhole power generation tools that would usually require additional field specialists.

At depth, the eMAT/GS Tool receives power from a surface power supply. This allows trapped hydraulic pressure to vent, which retracts the dogs of the GS component, and leaves the payload in the well.

APPLICATIONS

- Deploy or recover downhole equipment with a GS fish neck on e-line
- Wireline fishing
- Deployment in deviated wells

FEATURES AND BENEFITS

- Proven slickline techniques available on e-line
- Allows release of downhole components on e-line without jarring
- Allows retrieval of downhole tools with a safe option to emergency release if stuck in hole
- Rated to 10,000 psi [68.9 MPa], 347 degF [175 degC]
- Able to be configured to positive/negative polarity
- Simple to redress
- Robust design

TECHNICAL INFORMATION

Nominal GS Tool OD, in	Max. Tool OD, in	Length, in [mm]	Pressure Rating, psi [MPa]	Temperature Rating, degF [degC]
3 1/2	3.375	31.3 [795]	10,000 [68.9]	347 [175]
4	3.6	31.2 [792.5]		
5	4.5	31.6 [802.6]		



▲
eMAT/GS Tool

Product Code: eMat/GS Tool / 270

info@peakwellsystems.com | peakwellsystems.com

© 2021 Peak Well Systems Pty Ltd. All rights reserved. Revision: 15 October 2021



Multi-Action Pulling Tool

The Peak Multi Action Pulling (MAP) Tool facilitates the recovery of a wide range of downhole equipment fitted with external fishing necks without the need for separate tooling to pin up or release the pulling tool.

The Peak MAP Tool has a unique and versatile latch system to tackle external fishing necks with varying connections and lengths and can be configured for 'jar down', 'jar up' or 'double jar down release' to set and retrieve tools downhole. With an inbuilt indicator to display the configured jar release mode, the Peak MAP Tool improves safety and allows for a quick change between operating modes.

The adjustable core feature allows the Peak MAP Tool to be altered to suit any reach requirement. The latch release sleeve enables the tool to be detached from the fishing neck at surface with no special releasing tool requirement.

With its simplified design mechanism, no specialist tooling is required for redressing or pinning, the Peak MAP Tool simplifies inventory, reduces cost and improves operational efficiency.



APPLICATIONS

- Deploy or recover downhole equipment

FEATURES AND BENEFITS

- Increased operational flexibility from a single tool via 'multi-action jar down'/'jar up'/'double jar down for release', reducing inventory
- Single adjustable core for all connections - BC/QC/SR/rope socket including flat topped rope sockets for industry standard standing valves
- Visual indicator of core position for standard industry connections and shear mode to minimize scope for operator error
- Simple, robust design; pawl free for reliable service, ease of redress and minimized components
- Rapid redress via shear pin alignment between upper core and body; re-pinning achievable without the need for a pinning tool
- High strength latching dogs for medium-duty service
- No separate tooling to pin up, release or retrieve

TECHNICAL INFORMATION

Nominal Size, in	Actual OD, in	To Latch, in	Pulling Capability			
			Rope Socket, in	SR Fish Neck, in	Quick Connect, in	Button Connect, in
2.0	1.839	1.375	1.375	1.375 (15/16-in SR / 1 1/16-in SR)	1 1/2	1 1/2
2.5	2.205	1.750	1.750	1.750 (1 1/16-in SR / 1 3/8-in SR)	1 7/8	1 7/8
3.0	2.710	2.313	2.313	2.313 (1 9/16-in SR / 2-in SR)	2 1/2	2 1/2
4.0	3.583	3.125	3.125	3.125 (2-in SR)		



Product Code: Peak Multi-Action Pulling (MAP) Tool / 250

info@peakwellsystems.com | peakwellsystems.com

© 2017 Peak Well Systems Pty Ltd. All rights reserved. Revision: 13th May 2015





Wellbore Cleanup & Debris Removal

Simple Safe Assured

High Temperature/High Strength Magnet

The High Temperature/High Strength Magnet is used to recover loose ferrous objects from within a well.

Unlike normal magnets, the Peak magnetic insert can withstand prolonged exposure to very high downhole temperatures without losing magnetic strength.

APPLICATIONS

- Recovery of ferrous objects such as parted pulling tool dogs, perforating gun debris, corrosion scale, etc.

FEATURES AND BENEFITS

- Rated for extreme high-temperature
- Suitable for oil and gas environments with high resistance to CO₂ and H₂S
- Ensured recovery of ferrous objects with powerful magnetic insert
- Available in a range of sizes to suit application and well geometry
- Effective conveyance into the well enabled by stainless steel shroud
- Customized magnet designs available

MAGNETIC PERFORMANCE TABLE †

Contact Point	Magnet Assembly OD, in					
	1.750	2.220	2.720	3.500	3.750	4.500
1 5/16-in SR Thread	140 lbm	210 lbm	235 lbm	250 lbm	250 lbm	275 lbm
1 1/4-in SR Thread	175 lbm	245 lbm	265 lbm	300 lbm	300 lbm	320 lbm
1 1/2-in UN Thread	100 lbm**	230 lbm**	380 lbm	460 lbm	460 lbm	500 lbm
2-in UN Thread	N/A	150 lbm**	345 lbm**	565 lbm	565 lbm	650 lbm

† For reference only. Not all sizes listed.

** Magnet stands off contact point so full face contact is not made.

TECHNICAL INFORMATION

Tool OD, in [mm]	Temperature Rating, degF [degC]
1.250 [25.4] - 8.000 [203.2]†	500 [260]

† Contact a Peak Well Systems representative for OD and connection options within this range.



▲ High Temperature/High Strength Magnet

Product Code: High Temperature/High Strength Magnet / 115

info@peakwellsystems.com | peakwellsystems.com

© 2021 Peak Well Systems Pty Ltd. All rights reserved. Revision: 11 October 2021



Interchangeable Ring Broaching Tool

The Interchangeable Ring Broaching Tool is used for removing scale and debris from the tubing wall. Interchangeable Rings are slipped over a Central Mandrel and secured in place by the Top Sub. The Rings are supplied in various OD's to suit the Tubing ID.

The Central Mandrel is ported to allow maximum bypass. This feature reduces any hydraulic cushioning effect when jarring down to remove debris and prevents the build up of debris above the tool.

An optional Bottom Sample Cup allows scale and other debris to be recovered to surface for further analysis.

APPLICATIONS

- Removal of scale, sand, perforation damage and wax from the inside of tubulars

FEATURES AND BENEFITS

- Ported Mandrel for added bypass
- Interchangeable Broaching Rings
- Optional Sample Cup for retrieving debris sample for analysis
- 360 degree effective cutting face
- Simple to redress
- Robust design
- Inventory reduction

TECHNICAL INFORMATION

Nominal Tubing Size, in	Actual OD, in	Broaching Rings OD, in
2 3/8	1.500	1.750 - 1.900
2 7/8	1.654	1.900 - 2.400
3 1/2	2.000	2.250 - 2.890
4 1/2	2.750	3.000 - 3.950
5 1/2	3.750	4.000 - 4.890

Note: Custom sizes available on request.



All standard industry connections available

Product Code: Interchangeable Ring Broaching Tool / 108

info@peakwellsystems.com | peakwellsystems.com

© 2017 Peak Well Systems Pty Ltd. All rights reserved.

peak 
WELL SYSTEMS

Pump Bailer

The Pump Bailer is designed to recover sand, gravel, gun debris or other loose fill from above or inside any subsurface flow control device.

The Pump Bailer operates on the fundamental lift pump and piston principle. During the upstroke of the Bailer, suction is created, drawing in debris through the Bailer Check Sub where it is retained. A ball check valve, integral to the internal rod assembly allows maximum downstroke for continuous debris recovery until the chamber is full.

APPLICATIONS

- Recovering loose sand, gravel or gun debris from inside flow control devices
- Obtaining bottom hole debris samples for analysis

FEATURES AND BENEFITS

- Bailer length, shoe, shoe length and checking device can be supplied to suit customer requirements
- Bottom subs available: Half mule, Full mule, Castleated, Snorkle
- The intermediate checking device ensures the shoe is changed independently reducing unnecessary expense if component requires replacing due to onsite modification or damage
- Shortened bailer shoes ensure less downward travel required for optimal debris recovery
- Inventory reduction due to interchange ability of parts between Peak Drive Down, Pump and Hydrostatic Bailers
- Incorporating robust Stub Acme threads reduces likelihood of threads galling during continuous make up and break out of components where debris may be present
- Robust design

TECHNICAL INFORMATION

Nominal Tubing Size, in	Actual OD, in
2 3/8	1.500
2 3/8	1.750
2 3/8 / 2 7/8	1.875
2 7/8	2.250
3 1/2	2.500
4	3.000
4 1/2 / 5 1/2	3.500

Note: Customized Bailers can be made to suit customer requirements.



Product Code: Pump Bailer / 114

info@peakwellsystems.com | peakwellsystems.com

© 2020 Peak Well Systems Pty Ltd. All rights reserved. Revision: 9th October 2020



Hydrostatic Bailer

The Hydrostatic Bailer is designed to recover sand, gravel, gun debris or other loose fill from above or inside any subsurface flow control device.

Due to the force exerted as a result of larger piston areas, the 3-in and 3 1/2-in version incorporates a unique Trip Key system that removes the requirement for long, drawn out hydrostatic and shear pin strength calculations. The Trip Keys hold the travelling Internal Plug in place until jarring down shears the 1/4 in shear screws. The mandrel will then move up and the keys, which are no longer supporting the Internal Plug, retract causing the Internal Plug to accelerate upward creating an increased suction (in conjunction with the higher external pressure) which draws debris into the Bailer through the Bailer Check Sub.

The 3-in, 2 1/2-in, 2 1/4-in, 1 7/8-in, and 1 3/4-in versions incorporate a pressure retaining Single or Multi-Pin Sub which seals in atmospheric pressure at surface. The Multi-Pin Sub allows the operator to select the number and type of pins depending on the differential pressure and operational application. The bailer is activated by jarring down and shearing the selected pins in the Multi-Pin Sub.

APPLICATIONS

- Recovering loose sand, gravel or gun debris from inside hard to reach flow control devices

FEATURES AND BENEFITS

- Trip key design means shear pin/screw sees no direct loading from well pressure
- Safe Break design - three equalizing functions
- Bailer length, shoe, shoe length and checking device can be supplied to suit customer requirements
- Bottom Subs available: Half Mule, Full Mule, Castleated, Snorkle
- No requirement for long, drawn out hydrostatic or shear pin strength calculations
- The intermediate checking device ensures the shoe is changed independently reducing unnecessary expense if component requires replacing due to onsite modification or damage
- Inventory reduction due to interchange ability of parts between Peak Drive Down, Pump and Hydrostatic Bailers
- Incorporating robust Stub Acme threads reduces likelihood of threads galling during continuous make up and break out of components where debris may be present

TECHNICAL INFORMATION

Actual OD, in	Shear Out Device
1.500	Multi Pin
1.750	Single Pin
1.875	Single Pin
2.250	Multi Pin
2.500	Multi Pin
3.000	Multi Pin and Trip Key
3.500	Trip Key

Note: Customized Bailers can be designed to suit customer requirements.



Product Code: Hydrostatic Bailer / 114

info@peakwellsystems.com | peakwellsystems.com

© 2020 Peak Well Systems Pty Ltd. All rights reserved. Revision: 9th October 2020



Drive Down Bailer

The Drive Down Bailer can be used to recover hard packed sand, gravel or gun debris from above or inside any subsurface flow control device.

Often used in applications where the accumulated debris is hard in texture and difficult to break up, the Drive Down Bailer, being of strong design and incorporating few moving parts, is ideal to "jar" into and loosen up hard debris. As the Bailer enters the fill, the flapper or ball is pushed "off-seat", collects the debris to be recovered and closes as the Bailer is removed - containing the debris and allowing it to be retrieved to surface. The Drive Down Bailer may also be used to acquire bottom hole debris samples for analysis.

APPLICATIONS

- Recovering hard packed sand, gravel or gun debris
- Obtaining bottom hole debris samples for analysis

FEATURES AND BENEFITS

- Optional Drive Down Shoes including Serrated Flat Bottom, Castleated, Mule and Half Mule Shoe
- Optional intermediate checking devices including flapper, ball and junk catcher type
- Robust design
- The intermediate checking device ensures the shoe is changed independently reducing unnecessary expense if component requires replacing due to onsite modification or damage
- Shortened bailer shoes ensure less downward travel required for optimal debris recovery
- Inventory reduction due to interchange ability of parts between Peak Drive Down, Pump and Hydrostatic Bailers
- Incorporating robust Stub Acme threads reduces likelihood of threads galling during continuous make up and break out of components where debris may be present

TECHNICAL INFORMATION

Nominal Tubing Size, in	Actual OD, in
2 3/8	1.500
2 3/8	1.750
2 3/8 / 2 7/8	1.875
2 7/8	2.250
3 1/2	2.500
4	3.000
4 1/2 / 5 1/2	3.500

Note: Customized Bailers can be made to suit customer requirements.



Product Code: Drive Down Bailer / 114

info@peakwellsystems.com | peakwellsystems.com

© 2020 Peak Well Systems Pty Ltd. All rights reserved. Revision: 9th October 2020



Dump Bailer

The Peak Dump Bailer is designed to be run on the bottom of a toolstring to transport various fluids to a given depth within a wellbore.

By simple manipulation of the toolstring the fluid can then be expelled from the dump bailer leaving it at a pre-determined depth within the well.

APPLICATIONS

- Dumping cement on top of permanent plugs
- Depositing acid at scale restrictions
- Depositing acid on flow control items that may be scaled up preventing recovery

FEATURES AND BENEFITS

- Available with standard slickline connections
- Simple, robust design
- Easy and quick field redress
- Can be supplied in modular design allowing field changeable variations in length
- Can be supplied with various burst discs to suit every application
- Cost-effective method of transporting fluids to given point within the wellbore

TECHNICAL INFORMATION

Nominal Tubing Size, in	Actual OD, in
2 3/8	1.750
2 3/8 / 2 7/8	1.875
2 7/8	2.250
3 1/2	2.500
4	3.000
4 1/2 / 5 1/2	3.500

Note: Customized Bailers can be made to suit customer requirements.



Product Code: Dump Bailer / 114

info@peakwellsystems.com | peakwellsystems.com

© 2017 Peak Well Systems Pty Ltd. All rights reserved. Revision: 24th July 2015

peak 
WELL SYSTEMS

Radial Brush System

The Radial Brush System has been developed to assist in the cleaning of downhole nipple profiles and associated completion components.

The design incorporates a series of interchangeable radial brush rings assembled on a common mandrel. The use of a common mandrel means a reduced inventory as the same mandrel can be utilized for a range of different brush sizes to suit various completion designs. As the tool utilizes a series of brush rings it can be configured with brushes of different diameters thereby providing a tapered brush effect. The brush bristles can be supplied in various stiffness' and several different materials such as phosphor bronze, stainless steel etc.

APPLICATIONS

- Scale debris removal from sub surface safety valves (SSSV) and nipples
- Wax removal
- Pre-cleaning of casing/tubing wall prior to setting patches or packers
- Cleaning riser and tubing hanger bores

FEATURES AND BENEFITS

- Reduced inventory due to common mandrel across a given size range
- Brushes available with different bristle stiffness'
- Brushes available with bristles from various materials
- Multi-ring design allows for different brush sizes to be run at the same time
- Reduced redress cost as bristle wear may be limited to only one brush ring out of the set of three
- Can be supplied with a Sucker Rod Bottom Sub to connect a series of brushes

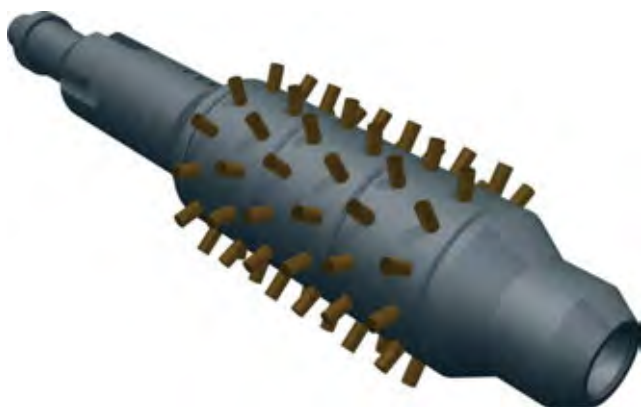

Product Code: Radial Brush System / 142

info@peakwellsystems.com | peakwellsystems.com

© 2017 Peak Well Systems Pty Ltd. All rights reserved.

peak 
WELL SYSTEMS

Torque Action Debris Breaker

The impact-driven Torque Action Debris Breaker (TADB) is deployed downhole to break up concretions of sand and scale which are resisting removal by other methods.

The TADB is jarred down mechanically in the well. The unique helically split torque sub applies a short duration torque to the TADB cutter below with each downward jar. The main torque body comes in 1 1/2 in, 1 7/8 in and 2 1/2 in, and has a number of different shoe sizes which can be easily changed on the main body of the tool as the scale is broken down. The debris is recovered by subsequent bailer runs.

APPLICATIONS

- To break up persistent sand/scale concretions which have resisted recovery by other methods

FEATURES AND BENEFITS

- Integral sprung torque system which applies torque to the cutting edges with each downward jar
- Internal support sleeve to limit loading on the torque spring should the tool become wedged in solids
- Left hand threads, where required, to prevent tool back-off down-hole
- Comes with different shoe sizes that are changed out on the same main tool body
- No other specialist tools required
- Overall reduction in time required for descaling, thus reducing intervention time and costs
- Production can resume much faster than ever before using alternative methods of descaling
- Delivers exceptional cost-effective results compared to other descaling alternatives such as mechanical, chemical or sonic break-down
- Full range of broach sizes available (1.700 in - 4.700 in); details upon request



▲ All standard industry connections available

Product Code: Torque Action Debris Breaker / 117

info@peakwellsystems.com | peakwellsystems.com

© 2017 Peak Well Systems Pty Ltd. All rights reserved.



peak 
WELL SYSTEMS



Roller Systems

Simple Safe Assured

Clamp-On Roller Centralizer

The clamp-on roller centralizer is designed to affix to and centralize wireline tools such as slim cement mapping tools (SCMT's) to allow deployment in high-angle, deviated wellbores.

The Peak design allows easy adaptability to any wireline tool that has a dogbone OD and comes in a range of sizes to suit the well geometry. The centralizer sits free on the shaft and is kept in position by the larger OD's on either side. The integral rollers reduce the contact area of the centralizer against the tubing wall and the body of the roller sub ensures that there is sufficient bypass when dropped in fluid.

APPLICATIONS

- To centralize wireline tools to acquire good quality well data in high-angle wells or where the liner top prevents wireline centralizers from collapsing
- Rollerized design allows for deployment in high angle, deviated well bores

FEATURES AND BENEFITS

- Ability to operate successfully in high angle, deviated wellbores
- Robust design with minimal components
- Designed to suit all Peak and third-party wireline tools
- Dual securing application with large screws designed to locate into grooves and lateral clamping mechanism to ensure clamp-on roller centralizer is firmly secured
- Rollers supplied in AISI 4140, 316 Stainless Steel, Nylatron or as specified by customer
- Interchangeable rollers increase the operating range of the centralizer and provide the end user with effective options

TECHNICAL INFORMATION

Tool OD, in	To suit	Length, in	Roller effective diameter, in
2.875	SLB SCMT	8.1	3.200-3.520



Clamp-On Roller Centralizer

Product Code: Clamp-On Roller Centralizer / 107

info@peakwellsystems.com | peakwellsystems.com

© 2021 Peak Well Systems Pty Ltd. All rights reserved.



Roller Stem

The Peak Roller Stem is designed to assist conveyance of a wireline toolstring into high angle, deviated wells.

The Roller Stem is designed to substitute a standard wireline stem and can be positioned along the length of the toolstring to lift the body and the weight of the string upon the axles of the rollers incorporated within the Roller Stem. This eliminates any friction between the toolstring body and the tubing wall. The Roller Stem has no welded parts and is fully field serviceable.

APPLICATIONS

- For use in high angle/deviated wells to assist toolstring conveyance

FEATURES AND BENEFITS

- Non-welded components
- Rollers supported on replaceable sintered bronze bushings which are fully field serviceable
- Double roller retention mechanism to ensure rollers remain locked in place
- Interchangeable rollers allow the stem to be optimally used in various sized well bores
- Multiple sized, interchangeable rollers available to suit varying tubing IDs or applications
- Rollers supplied in AISI 4140, 316 Stainless Steel, Nylatron or as specified by customer
- Supplied with connection options to suit customer requirements
- Special length and diameter rollers can be supplied to suit customer requirements
- Heavy duty robust design

TECHNICAL INFORMATION

Actual OD, in	Length, ft	Fish Neck, in	Minimum Roller OD, in	Maximum Roller OD, in
1.500	2, 3, 5	1.375	1.600	2.500
1.875	2, 3, 5	1.750	2.000	2.900
2.125	2, 3, 5	1.750	2.200	2.900
2.500	2, 3, 5	2.313	2.600	2.900



Product Code: Roller Stem / 132

info@peakwellsystems.com | peakwellsystems.com

© 2017 Peak Well Systems Pty Ltd. All rights reserved.



WellGlide

WellGlide* roller-centralizer sub reduces friction when conveying wireline toolstrings into high-angle deviated wells

Positioned along the length of the toolstring, the WellGlide sub lifts the string body onto the axles of its rollers, reducing friction between the toolstring body and tubing wall.

Interchangeable rollers adapt the WellGlide sub for various wellbore diameters, and its fluted body ensures enough bypass when running through fluids. The WellGlide sub can also centralize a running or pulling tool inside larger-bore tubulars.

APPLICATIONS

- High-angle deviated wells
- Fluid environments
- Running and pulling tool centralization in larger-bore tubulars
- Well interventions with Peak SIM* sealing integrity management system

FEATURES AND BENEFITS

- Provides standoff from tubing wall equivalent to OD of large lock mandrel
- Enables using one or more subs anywhere along the length of a conventional toolstring
- Reduces inventory requirements for sub bodies by using interchangeable rollers
- Increases operating range by using various diameter rollers
- Increases application range by using different material rollers including AISI 4140 steel, AISI 316 stainless steel, Nylatron®, or customer specifications
- Provides maximum bypass in fluid due to its fluted body
- Supplied with connection options to suit customer requirements
- Integrates with 2 11/16-in heavy-duty fishing string when supplied with ultra-heavy-duty (UHD) connection and neck.

TECHNICAL INFORMATION

Nominal Tubing Size, in	Fluted Body OD, in [mm]	Effective Roller Range, in [mm]
2 3/8	1.650 [118.1]	1.750–2.125 [44.4–54]
2 7/8	1.875 [47.6]	1.900–2.250 [48.3–57.2]
3 1/2	2.125 [54]	2.200–2.625 [55.88–66.7]
4 1/2	2.500 [63.5]	2.600–3.150 [66–80.1]
5 1/2	3.350 [85.1]	3.500–4.500 [88.5–114.3]
7	5.250 [133.4]	5.350–6.000 [139.7–152.4]

Note: Can be supplied with UHD connection and neck for use with 2 11/16-in heavy-duty fishing string.

*Mark of Schlumberger

Product Code: WellGlide / 107

info@peakwellsystems.com | peakwellsystems.com

© 2021 Peak Well Systems Pty Ltd. All rights reserved. Revision: 17 August 2021



▲ WellGlide with top views displaying interchangeable roller options



▲ All standard industry connections available



eWellGlide

eWellGlide is a fluted roller-centralizer sub designed to assist conveyance of a wireline toolstring into high-angle, deviated wells. It incorporates a central monoconductor or 22-pin for connection to an e-line tool.

eWellGlide is positioned along a toolstring to lift the body and weight of the string onto the axles of rollers incorporated in the eWellGlide roller sub and eliminate friction between the toolstring body and tubing wall.

Interchangeable rollers enable optimal functionality in wellbores of various sizes. The fluted body of eWellGlide ensures sufficient bypass when running through fluids and centralizes a running or pulling tool inside larger bore tubulars.

APPLICATIONS

- Central monoconductor or 22-pin enables signal
- Compatible with standard Schlumberger monoconductor or production logging tools
- Suitable for use in high-angle, highly deviated wells
- For centralizing running and pulling tools in larger bore tubulars
- Monoconductor eWellGlide is suitable for perforation operations

FEATURES AND BENEFITS

- Suitable for use in high-angle, highly deviated wells
- For centralizing running and pulling tools in larger bore tubulars
- Fluted body for maximum bypass in fluid
- Interchangeable rollers increase operating range and provide effective options to the end-user
- Lowers inventory requirements, lowering cost
- Multiple subs can be positioned anywhere along the toolstring
- NACE compliant
- Robust: available in stainless steel and Inconel material
- Harder, wear-resistant QPQ axles and rollers inhibit galling and extend service life

MONOCONDUCTOR TECHNICAL INFORMATION

Nominal OD, in	Max Tool OD (without rollers), in	Tool OD (with rollers) [†] , in	Length, in	Weight (with rollers) [‡] , lb	Pressure Rating, psi
3½	2.125	2.230 – 2.600	15.9	12.0	10,000
4½	2.500	2.750 – 3.350	15.9	13.0	10,000
5½	3.350	3.650 – 5.000	19.6	23.0	10,000

[†] Rollers available separately.

[‡] Approximate value based on roller selection.

22-PIN TECHNICAL INFORMATION

Nominal OD, in	Max Tool OD (without rollers), in	Tool OD (with rollers) [†] , in	Length, in	Weight (with rollers) [‡] , lb	Pressure Rating, psi
4½	2.500	2.750 – 3.250	19.0	14.0	10,000
5½	3.350	3.650 – 4.920	23.0	25.0	10,000

[†] Rollers available separately.

[‡] Approximate value based on roller selection.

Product Code: eWellGlide / 107

info@peakwellsystems.com | peakwellsystems.com

© 2020 Peak Well Systems Pty Ltd. All rights reserved. All rights reserved. Revision: 23rd June 2020.



Monoconductor eWellGlide

22-pin eWellGlide



Fluted Centralizer

The Fluted Centralizer is a one piece design that can be used to centralize a toolstring or lower BHA in the tubing string.

The Fluted Centralizer can also be used in some cases to drift the well bore. The fluted design allows for sufficient fluid bypass to enable efficient toolstring conveyance in well fluids.

APPLICATIONS

- To centralize a toolstring or lower BHA
- Specific drifting applications

FEATURES AND BENEFITS

- One piece robust design
- Special No-Go type designs can be supplied to enable tagging of the nipple profile
- The fluted design allows for sufficient fluid bypass which enables efficient toolstring conveyance in well fluids
- Bull Nose Bottom Subs available
- Connection options available to suit customer requirements



▲ All standard industry connections available



▲ No-Go type Fluted Centralizer

Product Code: Fluted Centralizer / 107

info@peakwellsystems.com | peakwellsystems.com

© 2017 Peak Well Systems Pty Ltd. All rights reserved.



Fluted Slip-Over Centralizer

The Fluted Slip-Over Roller Centralizer is designed to affix to and centralize a Wireline Cutter or Drop Bar to allow deployment in high angle, deviated wellbores.

The Peak design allows easy adaptability to any Cutter or Drop Bar and comes in a range of sizes to suit the well geometry. The integral rollers reduce the contact area of the Centralizer against the tubing wall and the fluted body of the Roller Sub ensures that there is sufficient bypass when dropped in fluid.

APPLICATIONS

- To centralize a Wireline Cutter or Drop Bar to prevent passing of Rope Socket/Cable Head when deployed
- Rollerized design allows for deployment in high angle, deviated well bores

FEATURES AND BENEFITS

- Ability to operate successfully in high angle, deviated wellbores
- Robust design with minimal components
- Designed to suit all Peak and third-party wireline cutters and drop bars
- Dual securing application with large grub screws designed to locate into grooves and lateral clamping mechanism to ensure Slip-Over Centralizer is firmly secured
- Rollers supplied in AISI 4140, 316 Stainless Steel, Nylatron or as specified by customer
- Interchangeable rollers increase the operating range of the Slip-Over Centralizer and provide the end user with effective options

TECHNICAL INFORMATION

To Suit, in	Minimum Body OD, in	Minimum Roller OD, in
1.500 Drop Bar	3.000	3.150
1.875 Drop Bar/Cutter	3.350	3.600
2.187 Drop Bar/Cutter	3.700	4.000

Note: Larger Roller available with increasing body OD.



Product Code: Fluted Slip-Over Centralizer / 107

info@peakwellsystems.com | peakwellsystems.com

© 2017 Peak Well Systems Pty Ltd. All rights reserved.





Bespoke Products

Simple Safe Assured

Telescoping Space-Out Joint

The Telescoping Space-Out Joint reduces rig time and problems associated with completion space-out, especially on subsea completions. The continuous bore between upper and lower completions aids well intervention operations in deviated wells.

The joint is shipped in the closed position then, on the rig floor, the transport pins holding the joint closed can be removed and the Telescoping Space-Out Joint fully stroked open. Rated shear pins are then inserted which will be sheared out when the lower end of the Telescoping Space-Out Joint lands off on the lower completion. The lower end can be supplied with various centralizer/mule shoe designs to suit particular applications.

APPLICATIONS

- Subsea workovers and completions
- Prevention of bottle necks between WEG and Liner Top
- Smart completions for easy land-off

FEATURES AND BENEFITS

- Fully rollerized to reduce friction at high angles
- Long stroke length - up to one standard joint
- Bell Guide lower end to locate and centralize on liner hanger
- Convex and concave rollers to match tubing radius
- Rig time cost savings
- Simplified completion space-out
- Slick bore from tubing hanger to bottom of the well allows for trouble free intervention



▲ Peak Well Systems' Telescoping Space-Out Joint is shipped in a collapsed state as shown and is extended prior to being run downhole.

Product Code: Telescoping Space-Out Joint / 600

info@peakwellsystems.com | peakwellsystems.com

© 2020 Peak Well Systems Pty Ltd. All rights reserved. Revision: 13th November 2020

peak 
WELL SYSTEMS

WellGuard Hydraulic Hold-Open Tool

The WellGuard Hydraulic Hold-Open Tool offers a hydraulic operated option for use on wells with pneumatic actuators operating the master valve.

Traditionally during well intervention on these wells, a fusible cap has to be installed on the pneumatic actuator rod to prevent undesirable closure should the ESD system be operated whilst wire/cable is across the master valve.

However in an emergency situation the master valve cannot be closed unless the fusible cap is removed or, in the worst cases, the heat of a fire melts the low melting point alloy.

WellGuard offers a hydraulic operated option to replace the fusible cap and ensure safety of the wellsite.

APPLICATIONS

- On wellheads that have a pneumatic actuator operating the master valve
- Where a fusible cap is no longer desirable as a means of preventing the master valve closing during emergency situations

FEATURES AND BENEFITS

- Simple design easily redressed offshore
- Can be adapted to suit various actuators
- Can be attached to the actuator temporarily for the duration of the well intervention
- Emergency fusible plug for worst case scenarios
- Allows for master valve control at the wireline panel

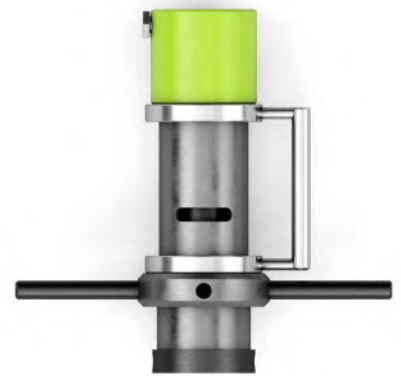

▲ WellGuard Hydraulic Hold-Open Tool

Product Code: WellGuard Hydraulic Hold-Open Tool / 904

info@peakwellsystems.com | peakwellsystems.com

© 2022 Peak Well Systems Pty Ltd. All rights reserved. Revision: 3 March 2022

peak 
WELL SYSTEMS



www.peakwellsystems.com

